

KVS, ZONAL INSTITUTE OF EDUCATION & TRAINING, CHANDIGARH



WORKSHEETS

CLASS : III

(All Subjects)

Mentor

SHRI. MUKESH KUMAR

DY. COMMISSIONER AND DIRECTOR

Edited & Compiled by

1. SH. VIPIN KUMAR, TA (PRIMARY)
2. SH. RANAJIT KONDHARE, TA (PRIMARY)

Look at the following words taken from the poem :

creep, trees, bees







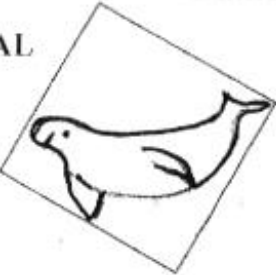

Underline the vowels in the words :

creep, trees, bees

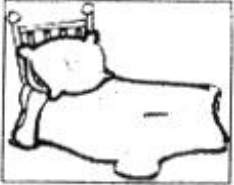
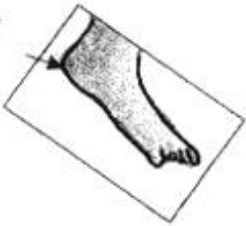
You have noticed that the vowels are same in the words and also their sounds :

ee

Now, put a in the box which has the words with the same vowel sounds and for different vowel sounds .

SEAL 	TEA 	BED 
HEEL 	TENT 	TEAM 
SEA 	SEED 	WHEEL 

TOPIC : Good Morning

I. Mark the 'ly' words in the maze :

M	N	S	L	O	W	L	Y	N	M
S	Q	U	I	C	K	L	Y	Q	X
T	E	H	A	P	P	I	L	Y	J
E	A	Y	J	L	S	A	D	L	Y
A	S	N	O	M	F	G	H	T	R
D	I	Q	Z	S	C	V	B	G	N
I	L	Q	L	O	V	E	L	Y	X
L	Y	Q	W	R	T	Y	U	I	O
Y	C	A	R	E	F	U	L	L	Y

II. Use any 'five' of the marked 'ly' words in sentences of your own :

1. _____
2. _____
3. _____
4. _____
5. _____

TOPIC : The Magic Garden

Write the words with the ending [suffix] - ful :
[an example is given]

joyful

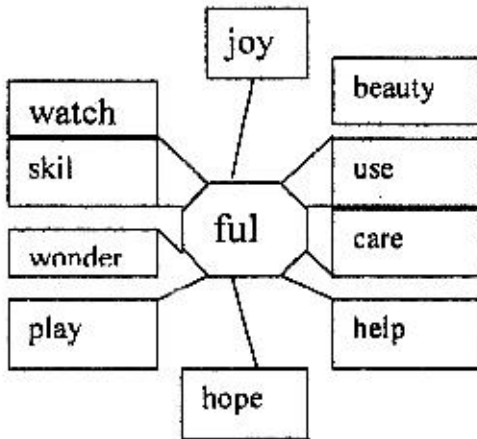





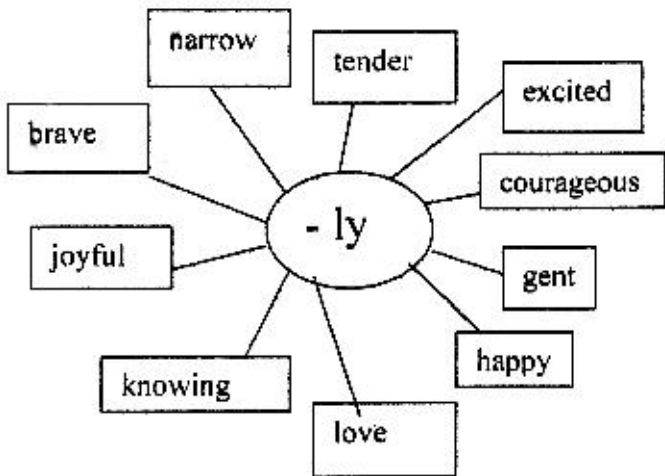



1. _____
2. _____
3. _____
4. _____
5. _____
6. _____
7. _____
8. _____
9. _____
10. _____

Join -ly and write the words :



- A. _____
- B. _____
- C. _____
- D. _____
- E. _____
- F. _____
- G. _____
- H. _____
- I. _____

I. Match the animals to their sound :

Animals		Sound
Crows		Bray
Birds		Crow
Bees		Neigh
Flies		Croak
Cocks		Caw
Frogs		Chirp
Donkeys		Hum
Horses		Buzz

II. Draw the bird from the clues :

a) My colour is green.
My beak is red.
I eat chillies.

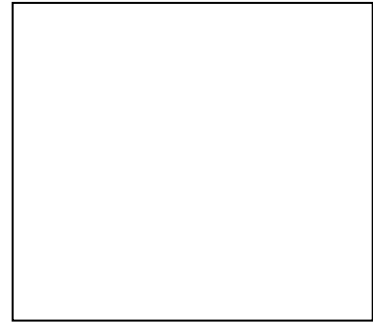

b) I have beautiful feathers.
I am the national bird of India.
I dance in rain.



III. Let us have rhyming fun with these words :

1. jay 

3. link 

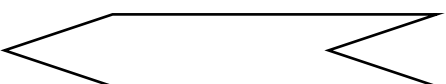
2. grow 

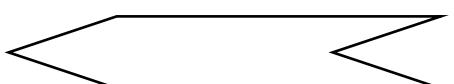
4. sunny 

I. You see different kinds of birds in the surroundings. Name any five of them :

- a) _____
- b) _____
- c) _____
- d) _____
- e) _____

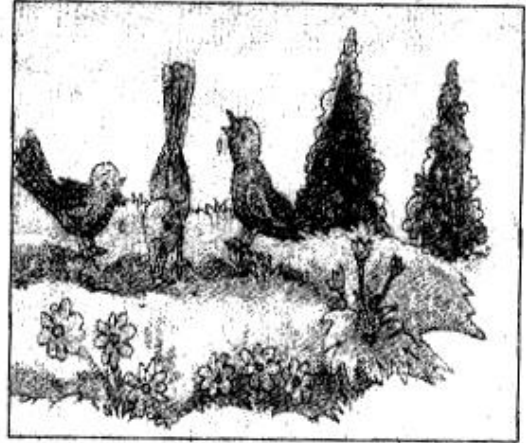

V. Write a suitable describer from the box for the pictures :

tall, thin, Big, Red, fast, ugly, ripe, beautiful

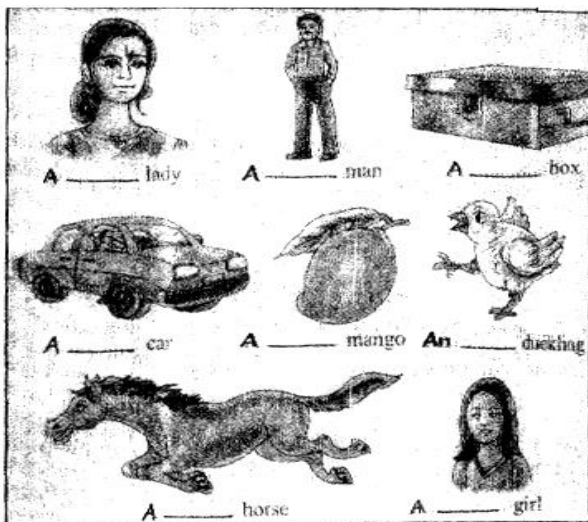

VI. Name a few things you eat or drink in a party.

- 1. _____
- 2. _____
- 3. _____
- 4. _____
- 5. _____

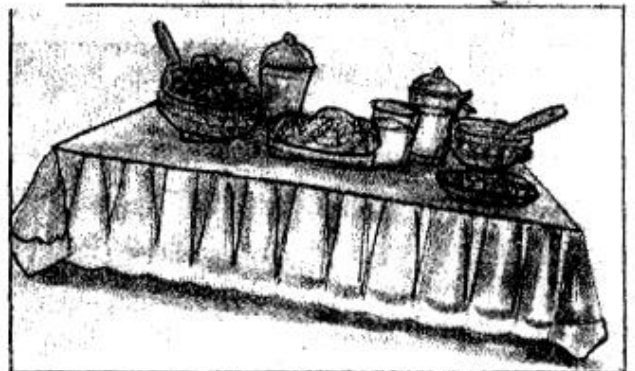

I. Arrange the following words from your text in alphabetical order :

Celebration, cradle, ceremony, courtyard, cruel,

Confident, chocolate, centre, colourful, camel

- | | |
|----------|-----------|
| 1. _____ | 6. _____ |
| 2. _____ | 7. _____ |
| 3. _____ | 8. _____ |
| 4. _____ | 9. _____ |
| 5. _____ | 10. _____ |

II. Use the clues and write the words :

- | | |
|---------------------------------------------|--------------------|
| 1. To bang at a door, we say | <u>k n</u> _ _ |
| 2. To make woolen things, we say | <u>k n</u> _ _ |
| 3. Part of the body below our thigh, we say | <u>k n</u> _ _ |
| 4. The joint of our fingers, we say | <u>k n</u> _ _ _ _ |
| 5. To tie up something, we put | <u>k n</u> _ _ |

[Note : The first letter K is silent in all the words]

III. Circle the silent letters in the following words :

- | | |
|------------|---------|
| 1. plumber | 2. hymn |
|------------|---------|

I. Help Nina to reach the baby sparrows by following the grains :

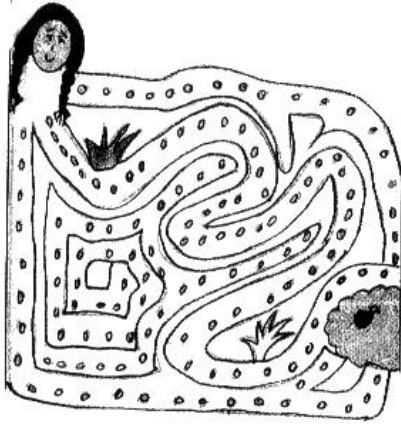

II. Do you have a pet at home ? Write a few sentences about it.



III. Pick out the words from the TOPIC to match these descriptions :

1. a young one :
2. place where birds live :
3. birds are covered with these :
4. a place with more shops :

TOPIC 5 : Little By Little

I. Name any six things that we get from trees :

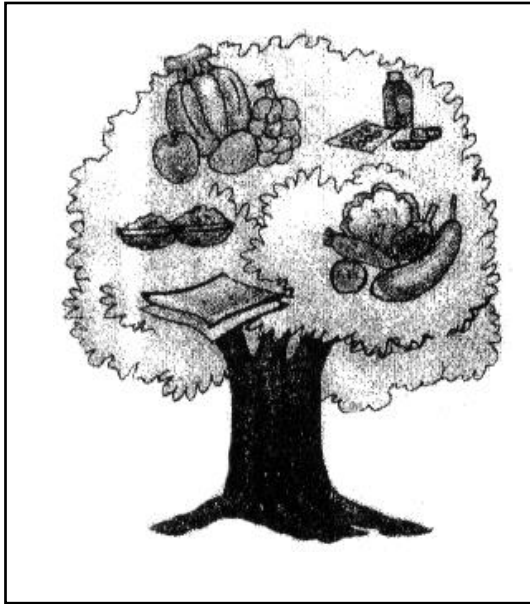

1. _____
2. _____
3. _____
4. _____
5. _____

II. Pick out the meanings of the words from the box given :

slender, little by little, huge, sipped, appeared, far and wide

1. slowly _____
2. drink slowly _____
3. delicate _____
4. mighty _____
5. spread over a large area _____
6. came out _____

TOPIC 5 : Little By Little

I. Read the clues given and complete the crossword puzzle :

			1F					1R
		3F					2L	
	2B							S
				3S				

ACROSS :

1. I am colorful
2. Birds sit and make nests on us
3. I grow above the ground

DOWNWARDS :

1. We grow under the soil
2. We are green
3. We have seeds and we are sweet

TOPIC: Enormous Turnip

I. Search the vegetables in this maze with the help of picture clues. Circle them with green if it grows above the ground and with red if it grows under the ground.

P	A	P	C	U	M	U	S	R	O	O	M
U	C	A	R	R	O	T	P	C	C	Z	W
M	U	S	R	R	M	A	I	A	A	C	X
P	O	T	A	T	O	M	N	P	U	U	B
K	N	U	A	O	O	O	A	S	L	C	R
I	I	R	D	M	M	O	C	I	I	U	I
N	O	N	D	A	A	P	H	C	F	M	N
P	N	I	C	T	T	N	W	U	L	B	J
U	I	P	C	O	R	N	Z	M	O	E	A
M	N	E	R	A	D	I	S	H	W	R	L
B	E	A	N	S	P	O	P	N	E	R	S
S	O	S	N	S	D	I	S	H	R	C	U



II. Observe the picture and write five sentences :

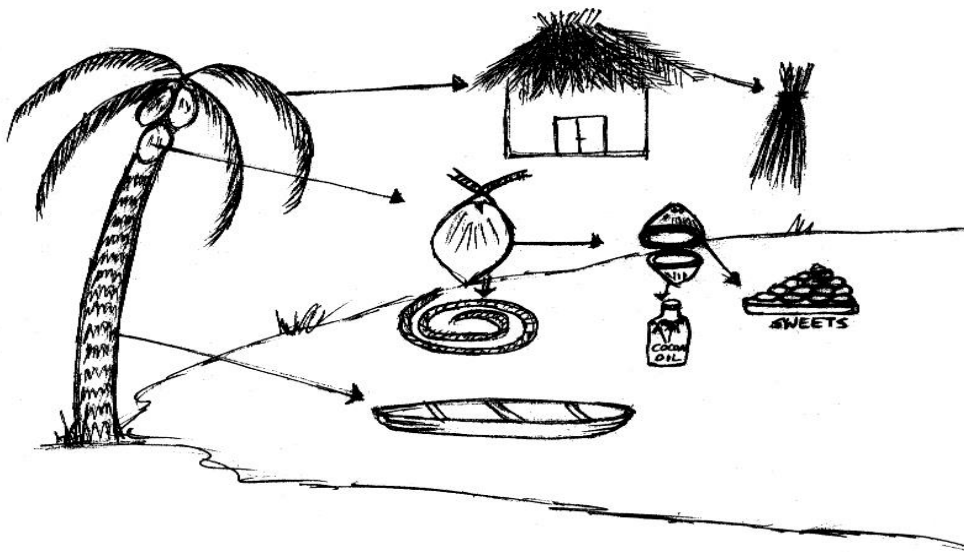

TOPIC: Enormous Turnip

I. Find the names of vegetables in the word search. Circle them :

K	S	P	I	N	A	C	H	Q
P	T	O	N	I	O	N	L	P
O	B	R	I	N	J	A	L	O
T	J	C	A	B	B	A	G	E
A	I	H	M	I	N	T	M	R
T	O	M	A	T	O	C	D	N
O	Y	A	B	U	G	E	F	S
N	M	C	A	R	R	O	T	L
C	A	P	S	I	C	U	M	T

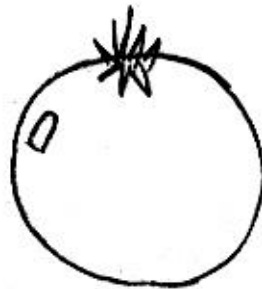
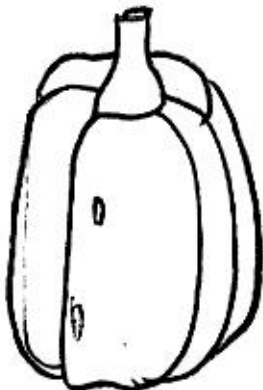
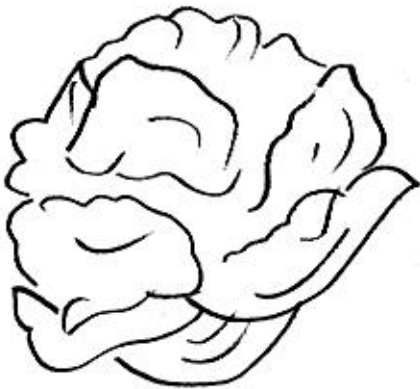

I. Look at the picture of the beach and write five sentences .

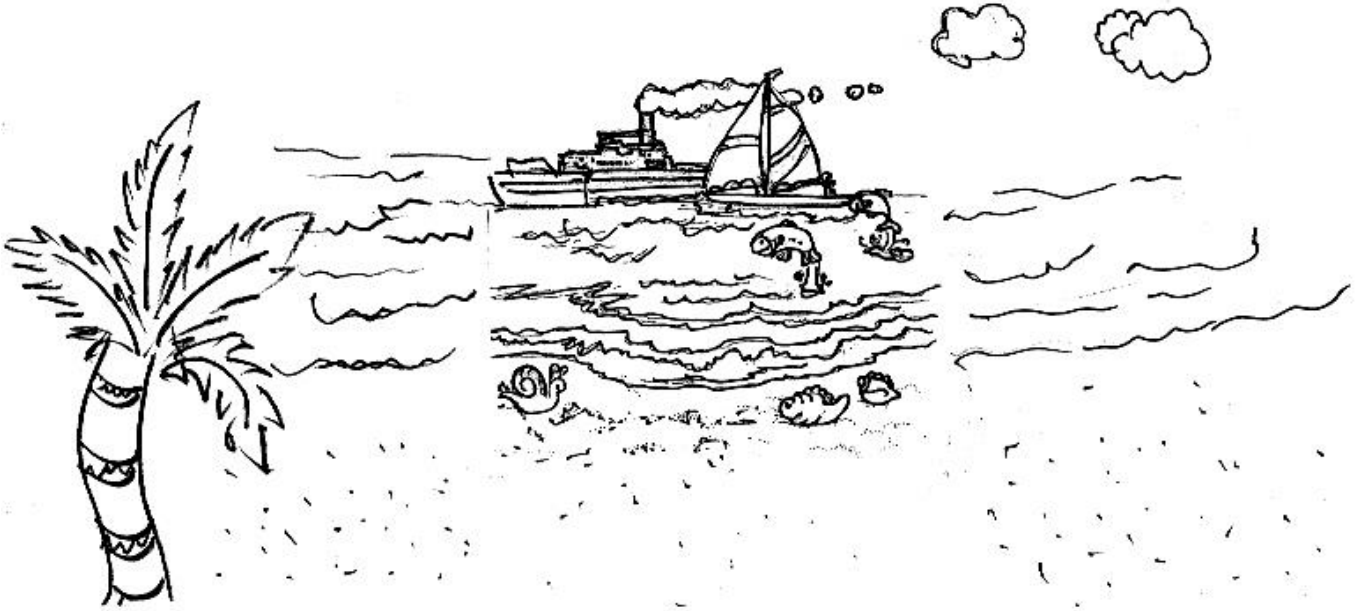

II. Pick out five items from the help box which you can find lying on sea beaches.

boat	lion	sand	ship	water
tiger	coconut	crab	net	snail

TOPIC : Sea Song

I. Write out three words which rhyme with the following words :

1. cold , ,

2. sound , ,

3. hand , ,

4. shook , ,

5. harm , ,

II. Pick out the suitable words denoting groups from the help box :

gang, swarm, chain, group, army, pair, bundle

1. a of mountains.

2. a of bees.

3. a of robbers.

4. a of sticks.

5. a of islands.

6. an of soldiers.

TOPIC : A Little Fish Story

I. Complete the sentences:

1. If I were a butterfly, I would

2. If I were a fish, I

3. If I were a peacock, I

4. If I were a duck, I

5. If I were a dolphin, I

6. If I were a millionaire, I

TOPIC : The Balloon Man

I. Write the words which are similar to the words given in these balloons. One is done for you :

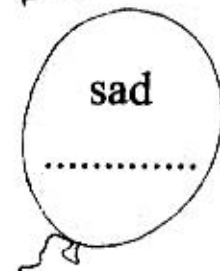
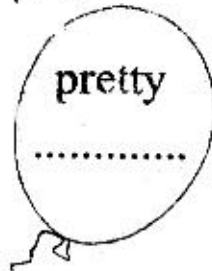
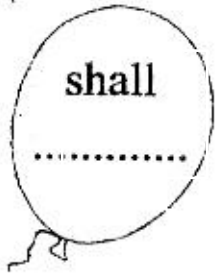
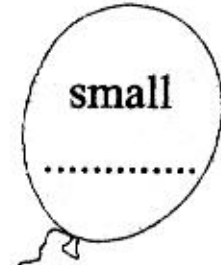
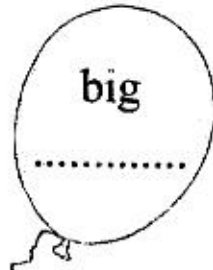
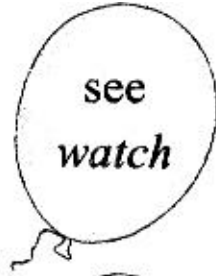

II. Write three rhyming words for these words :

- | | | | |
|-------|-------|-------|-------|
| day | | | |
| bunch | | | |
| stay | | | |
| high | | | |
| sky | | | |
| all | | | |

III. Name the color of :

your hair

your uniform

your parrot

1.

2.

3.

TOPIC : The Balloon Man

I. Circle the names of ten colors in this grid. One has been done for you.

B	L	A	C	K	O	R	S	P	U	O
R	D	E	M	M	P	Q	S	I	T	R
O	C	F	B	L	U	E	V	N	W	A
W	A	G	H	I	I	K	L	K	X	N
N	B	V	I	O	L	E	T	Y	X	G
Y	E	L	L	O	W	X	X	X	Y	E
Y	Y	Y	Y	Y	Y	Y	Y	Y	Y	Y
R	E	D	Z	Z	G	R	E	Y	O	O
A	O	O	W	H	I	T	E	O	O	O

II. Match these words to form new words. Write them.



.....



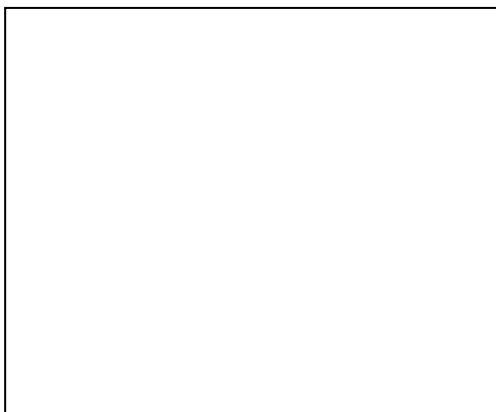







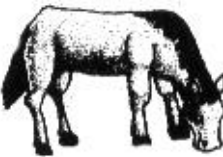



III. Draw balloons and write three sentences about it.



.....

TOPIC: The Yellow Butterfly

I. Match the animals with their homes :

Animals		Homes	
1.	 Horse	1.	 den
2.	 Bee	2.	 hole
3.	 Dog	3.	 stable
4.	 Lion	4.	 hive
5.	 Spider	5.	 kennel
6.	 Cow	6.	 shed
7.	 Snake	7.	 web

II. Join the dots and see what you have formed. Color it.

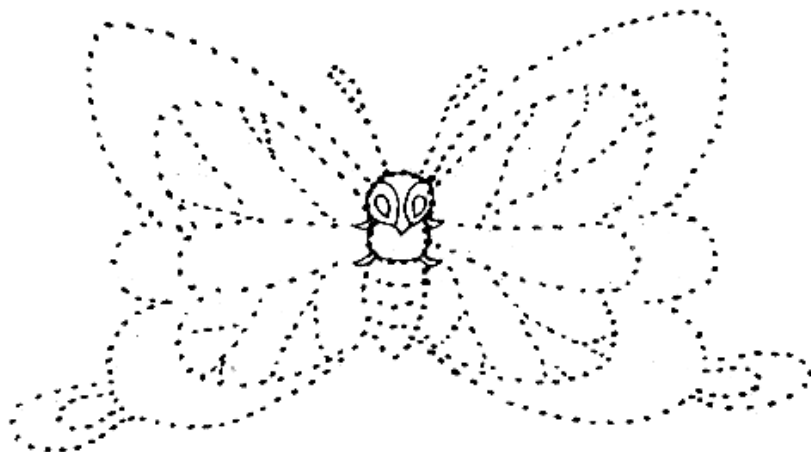

I. Complete the word train by starting the next word with the last letter of the previous word.

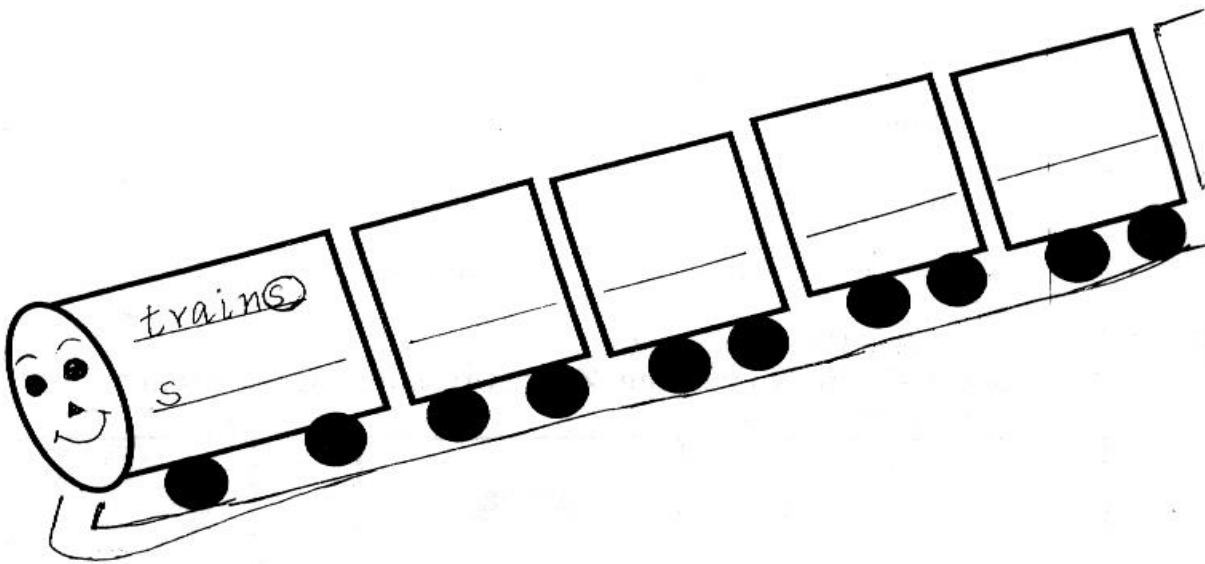

II. Encircle the correct spelling:

1. carring carying carrying
2. precious pracios presious
3. darkness darknes drakness
4. loods loads laods
5. dawne dwan dawn

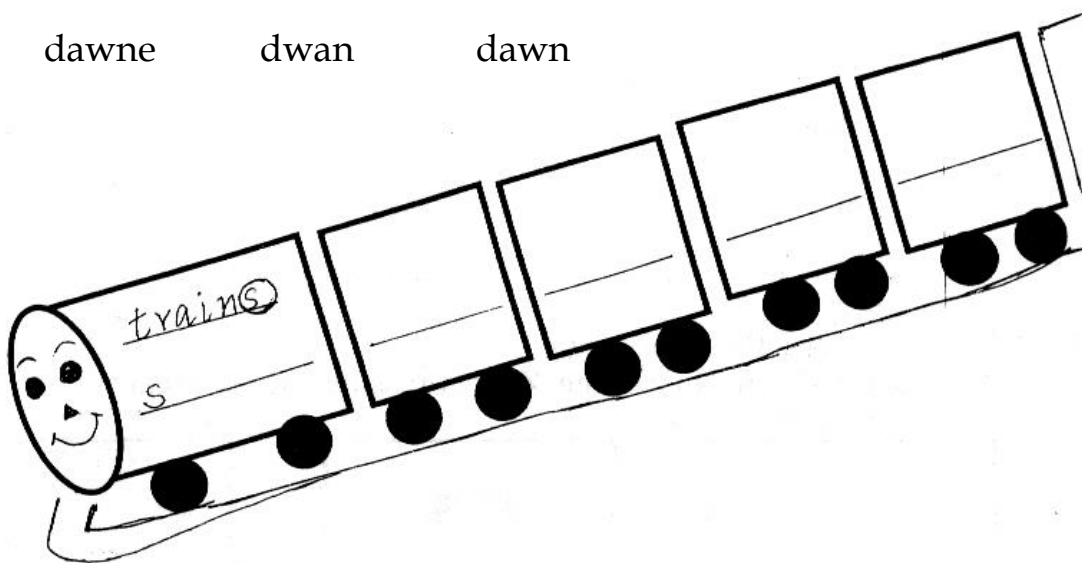

Describe the picture using the clues: [write five sentences] :

Platform, porter, luggage, coach, people,
Families, ticket, checker, loud speaker



TOPIC: The story of the road

I. Let us name the road signs given below :

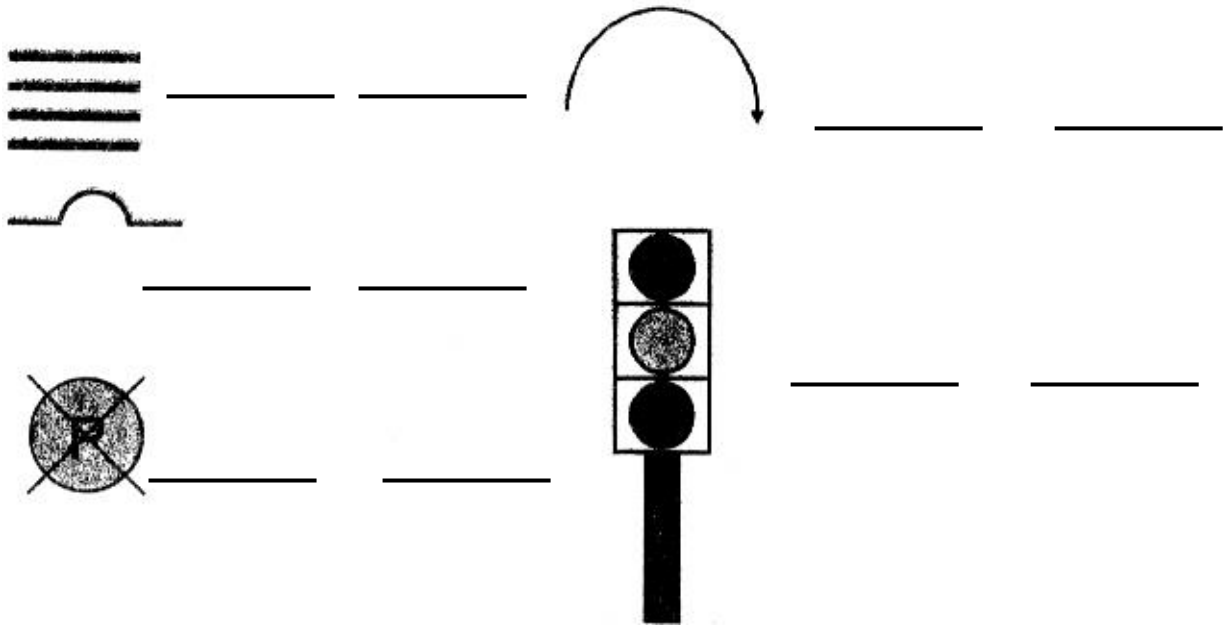

Make use of the help-box

U-turn, no-parking,
Zebra-crossing, traffic-light
Speed-breaker

II. Match the sounds with sound makers :

- | | |
|------------------|-------------------------|
| 1. sparrows | chatter-chatter |
| 2. crow | tring-a-ling |
| 3. children | chirrup-chirrup |
| 4. shoes | peas, cabbage |
| 5. bicycle | tramp-tramp |
| 6. vegetable-man | caw-caw |

TOPIC: The story of the road

II. Solve the puzzle about the people who help us.

Down

1. He looks after our teeth.
2. She looks after the passengers on an aero plane
3. He repairs water pipes and taps
4. He plans the design of our home

Across

5. She looks after the patients
6. He repairs electrical equipments
7. Carries our luggage

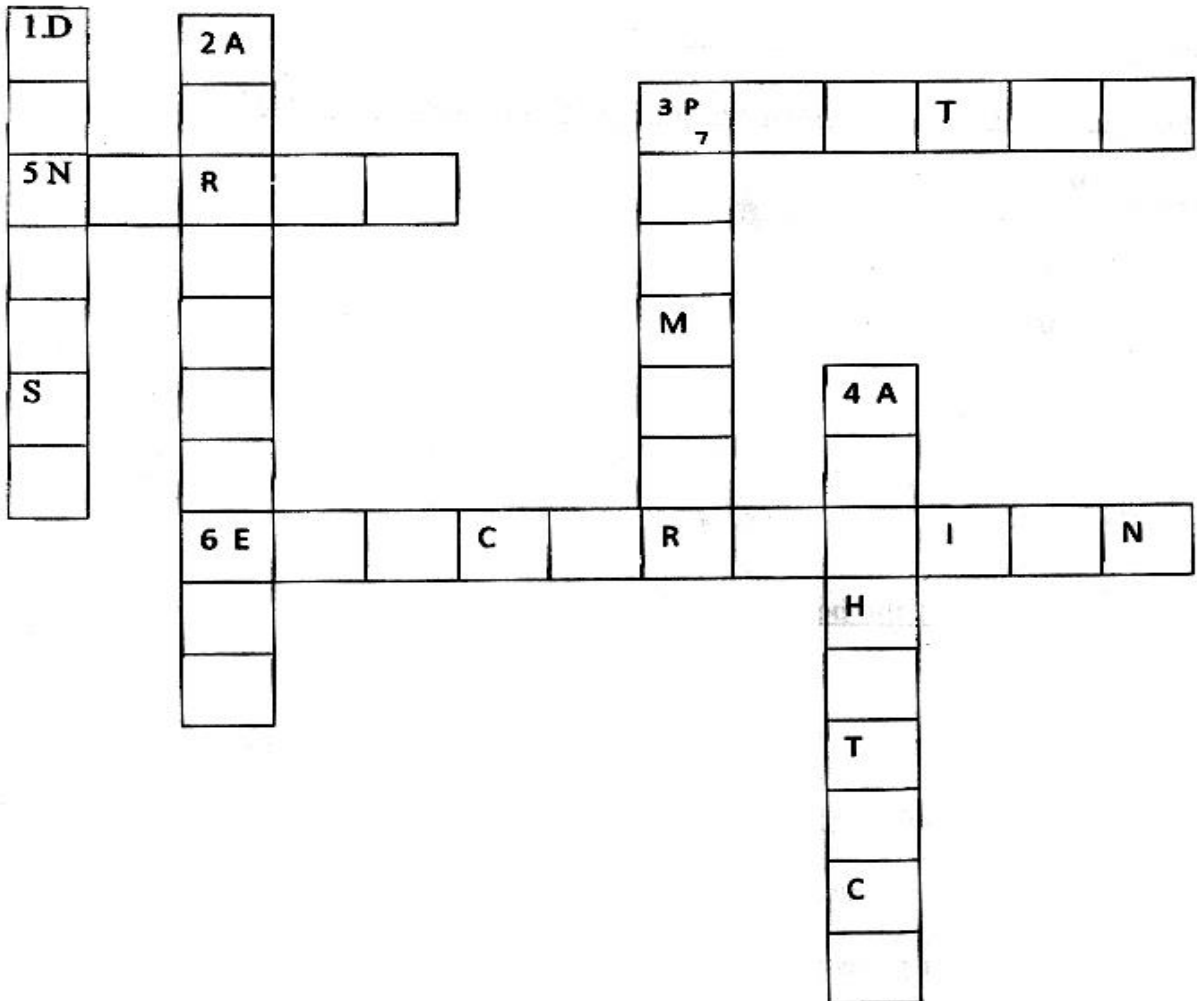

TOPIC: Puppy And I

I. Complete the sentences :

1. Give me some _____ to eat. [food/clothes]
2. I want to _____ across the river. [swim/walk]
3. The Aeroplane flies in the _____ [sky/road]
4. Cauliflower is a _____ [fruit/vegetable]
5. The birds _____ [mew/chirrup]

II. Name any five things that you happened to see on the way to school.

III. Make questions using can :

1. I can drive a car ?

Ans. _____

2. I cannot touch the sky ?

Ans. _____

3. I hear the sound of feet ?

Ans. _____

IV. Join and make phrases of the following :

1. a cluster of bees
2. a crew of robbers
3. a gang of stars
4. a shower of trees
5. a swarm of blessings

I. Solve the following puzzle about the animal homes.

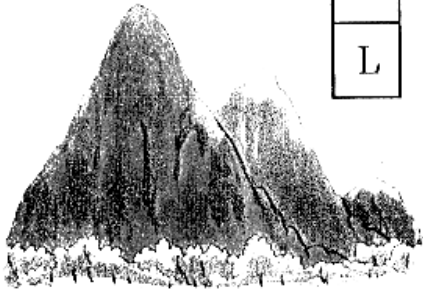
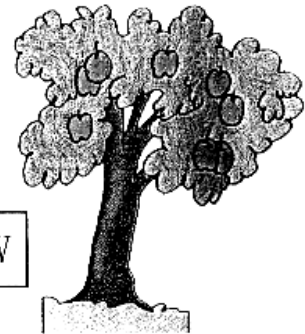
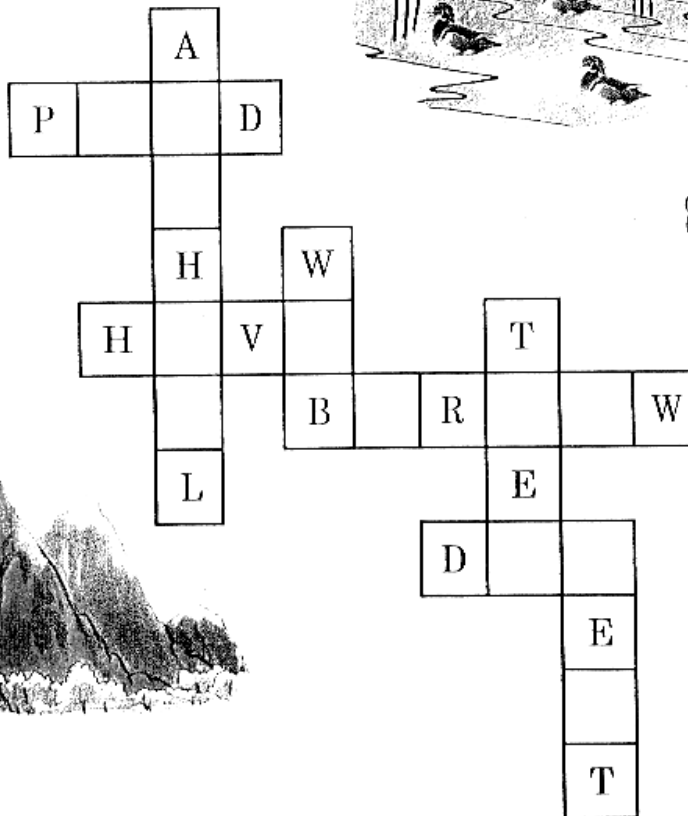
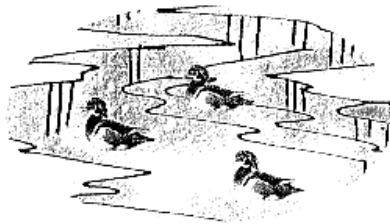
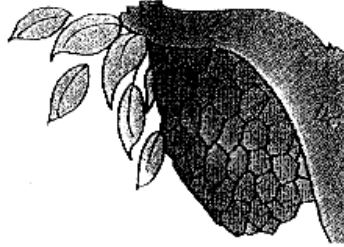
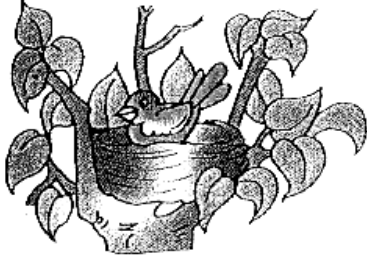

TOPIC: Little Tiger, Big Tiger

I. Mark the animals in the maze and list the animals :

1. _____

m	n	d	e	e	r	c	s	w
t	j	f	w	q	n	p	i	g
i	x	b	m	n	f	o	w	l
g	e	v	w	o	q	b	c	f
e	z	f	b	c	n	n	k	i
r	a	i	a	k	w	k	x	s
m	o	s	n	b	e	v	e	h
p	h	e	a	s	a	n	t	y
y	f	r	o	g	b	x	z	c

2. _____

3. _____

4. _____

5. _____

6. _____

7. _____

8. _____

II. Circle the right spelling :

bellowed belloed bellowed

twitched twiched tweeched

paaunsed paunsed pounced

glistened gleesened glissened

III. Match the right answer :

success opposite of above []

below double letters []

see rhymes with still []

skill phononym of sea []

TOPIC: Little Tiger, Big Tiger

I. Solve the puzzle about the people who help us.

Down

1. He looks after our teeth.
2. She looks after passengers on an aeroplane.
3. He repairs water pipes and taps.
4. He plans the design of our houses.

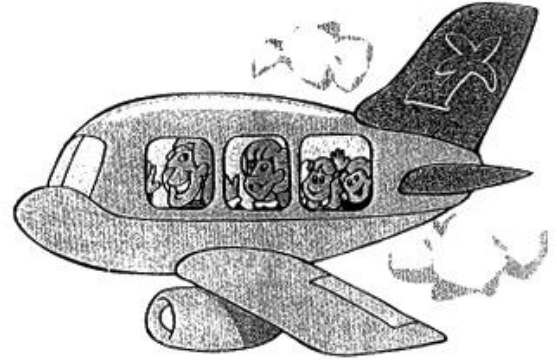

Across

5. She looks after the patients.
6. He repairs electrical equipments.
7. Carries our luggage.

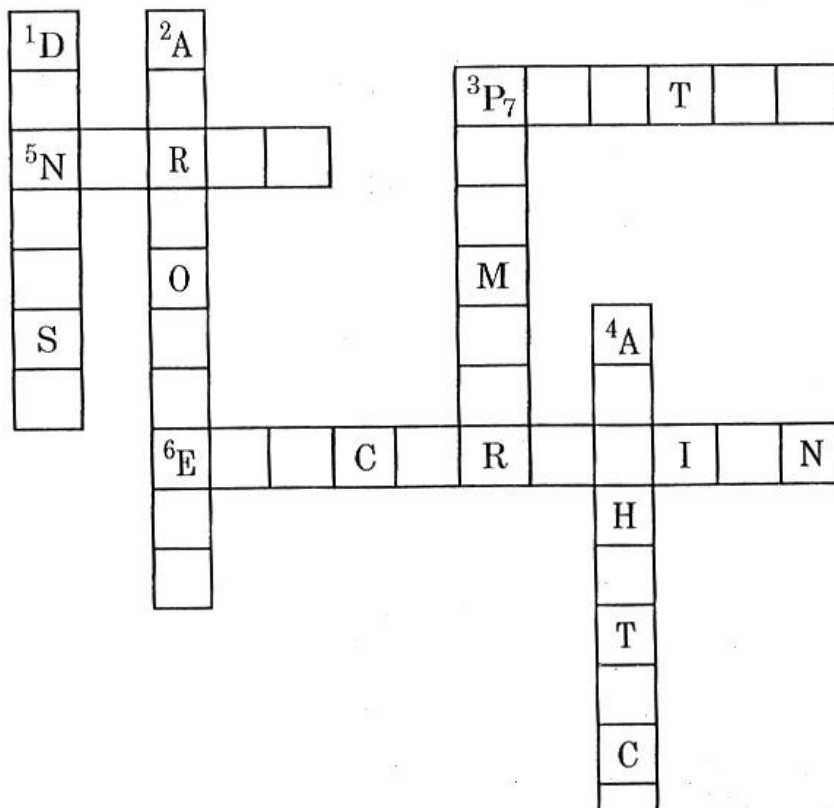

I. Identify and name the following :

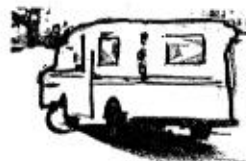
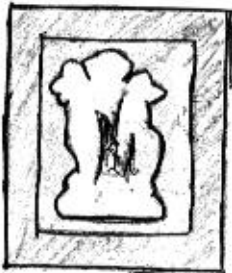
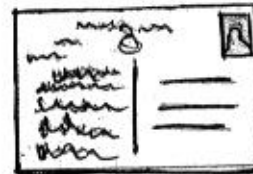
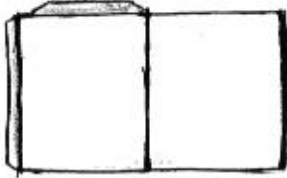

TOPIC: My Silly Sister

I. Fill in the blanks with the correct words :

walked talked showed played looked

walking talking showing playing looking

1. I was _____ with my grandfather over the phone.
2. My brother and I _____ on the ground yesterday.
3. My friends and I _____ to school last week.
4. The children are _____ on the stage.
5. Shyam _____ on the phone last night.
6. I _____ my dad what I found last week.
7. Sachin is _____ on the stairs right now.
8. My grandpa is _____ in the garden.
9. Asha _____ with the music yesterday.
10. Ram is _____ me where to put my books.

II. Encircle the correct word in the given sentences :

1. Savita [**blow, blew**] out the candles last night.
2. The teacher [**speak, spoke**] to my yesterday before school.
3. We [**take, took**] the bus to school last week.
4. The police dog [**come, came**] into my classroom today.
5. A big yellow bird [**fly, flew**] over my head.

I. Underline the pair of rhyming words in the following sentences.

E.g., : 1. Our ball bounced over the wall.



2. My pet is wet



3. The pig is big.



4. The dog is sitting on the log.



5. The bat likes to wear a hat.



6. A fish is dancing in the dish.



7. I see a bee in the tree.



8. The mouse is in the house.



I. It is rhyme time now. Copy a suitable word on the blank from the cloud.

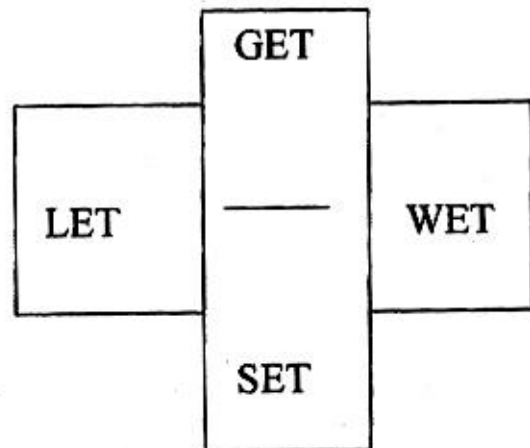
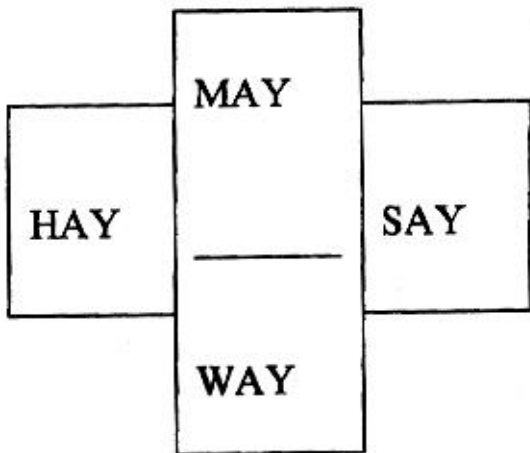
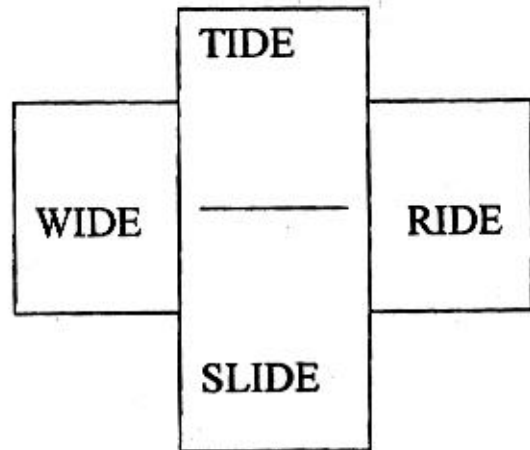
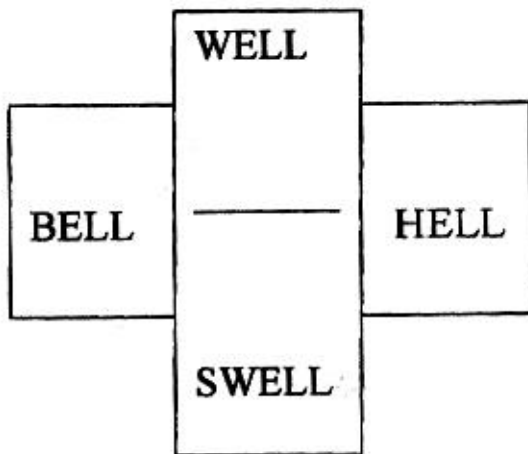

TOPIC: Don't Tell

- I. Read the clues and encircle the words related to people who help us in the crossword puzzle.

c	g	n	u	r	s	e	a	e	r	e	d
l	w		p	q	t	l	o	c	d	y	o
o	q	f	o	m		u	c	n	r	p	c
w	c	b	s	u	q	u	t	u	i	k	t
n	o	n	t	s	r	t	m	v	v	q	o
d	b	m	m	i	g	o	r	a	e	d	r
a	b	l	a	c	q	k	q	g	r	u	t
z	l	j	n	i	f	y	f	x	q	z	u
x	e	g		a	t	e	a	c	h	e	r
c	r	a	g	n	z	x	f	f		u	p
v	p	a	s	t	r	o	n	a	u	t	l
l	i	b	r	a	r	i	a	n	h	j	k

Write the words in the given space :

1. He drives motor vehicle _____
2. She teaches in a school _____
3. He mends our shoes _____
4. He plays musical instruments _____
5. He works in a library _____
6. He travels in a space craft _____
7. He brings our letters _____
8. He makes people laugh _____
9. She treats sick people _____

TOPIC : He is My Brother

I. Complete this family tree with the names of your relatives [like brother].

The first letter is given as a hint :



II. Here are a few signs for children who cannot hear. Write the words from the clue-box for these signs :

CLUE BOX
write, dance, lose, win, sing, read



1. _____



2. _____



3. _____



4. _____









5. _____







6. _____

TOPIC: How Creatures Move

I. How do these creatures move? Match them suitably.

- | | | | | |
|----|-------------------------------------------------------------------------------------|------------|-----|----------------------|
| 1. |  | a lion | [a] | crawls up a wall |
| 2. |  | a squirrel | [b] | wiggles all around |
| 3. |  | a fly | [c] | walks on padded paws |
| 4. |  | a seal | [d] | dives and swims |
| 5. |  | a worm | [e] | leaps |
| 6. |  | a monkey | [f] | hops on the ground |
| 7. |  | a bird | [g] | swings its tail |

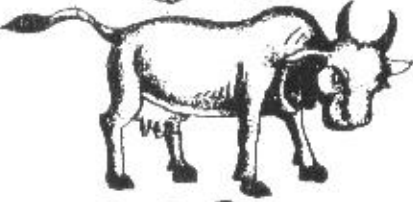
I. Match the following :

- | | | |
|----|-------------------------------------------------------------------------------------|--------------|
| 1. |  | [a] whiskers |
| 2. |  | [b] horns |
| 3. |  | [c] paws |
| 4. |  | [d] fins |
| 5. |  | [e] beak |
| 6. |  | [f] hoofs |

II. Complete these idioms :

- | | | |
|----|---------------|-------|
| 1. | as fast as a | _____ |
| 2. | as proud as a | _____ |
| 3. | as busy as a | _____ |
| 4. | as tall as a | _____ |



TOPIC: The Ship of the Desert

I. Encircle young ones of animals :

a	s	d	f	h	j	k	l	p	o	k	n
f	c	u	b	p	n	h	p	h	k	i	o
k	r	o	a	k	c	b	i	h	o	t	o
i	i	z	y	t	n	m	g	w	y	t	t
d	g	a	c	f	k	k	l	r	l	e	p
k	f	c	a	l	f	y	e	q	p	n	z
m	o	d	w	s	g	s	t	o	q	o	l
l	n	r	k	z	w	r	m	d	n	r	a
c	o	l	t	o	p	u	p	p	y	t	m
p	y	t	s	q	z	o	c	b	k	y	b
m	k	n	r	q	t	y	z	o	p	n	x
a	d	u	c	k	l	i	n	g	t	x	f

II. Find the movement / action words from the word - maze

W	I	G	G	L	I	N	G	B	S
R	S	Y	G	E	B	C	Q	S	W
I	P	H	M	A	R	R	L	I	I
G	R	O	O	P	E	A	C	N	N
G	E	P	T	I	A	W	D	G	G
L	A	P	Y	N	D	L	N	R	I
I	D	I	J	G	I	E	D	Y	N
N	R	N	D	A	N	C	I	N	G
G	F	G	E	R	G	Z	V	W	Q
W	D	T	F	L	Y	Q	E	C	P

ZONAL INSTITUTE OF EDUCATION & TRAINING, CHANDIGARH

Class: III

Sub: EVS

CLASS: III

TOPIC: WATER O WATER

DATE:

CIRCLE SIX SOURCES OF WATER IN THE PUZZLE:

A Q R I V E R G H L A K E M N P O N D R L S T R E A M N O C E A N F L S E A H R A I N H A N D F U M

2. WRITE THE RIGHT ONE



IVERR

.....



AIRN

.....



LLWE

.....



HELP THE BOY TO FIND HIS WAY.

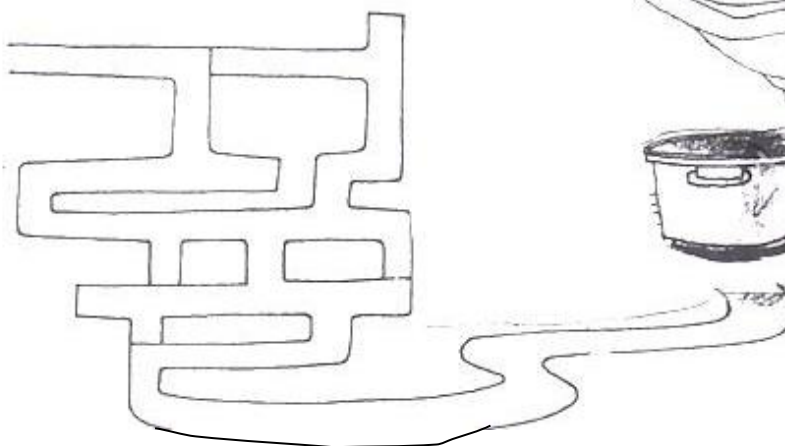

ZONAL INSTITUTE OF EDUCATION & TRAINING, CHANDIGARH

Class: III

Sub: EVS

CLASS: III

TOPIC: WATER'O WATER

DATE:

**FROM THE GIVEN WORD GRID FIND OUT THE NAME OF SIX RIVERS AND
WRITE BELOW:**

C	K	A	V	E	R	I	G
K	X	G	P	Q	R	T	O
R	Y	A	M	U	N	A	D
I	Z	N	Y	M	X	T	A
S	P	G	X	Q	R	M	V
H	N	A	R	M	A	D	A
N	F	D	U	X	P	Q	R
A	T	M	L	B	X	R	I

ZONAL INSTITUTE OF EDUCATION & TRAINING, CHANDIGARH

Class: III

Sub: EVS

CLASS: III

TOPIC : OUR FIRST SCHOOL

DATE :

FIND OUT THE FAMILY MEMBERS FROM THE GRID AND WRITE BELOW

G	R	A	N	D	F	A	T	H	E	R
R	X	Z	N	O	A	K	V	P	I	W
A	M	S	I	S	T	E	R	N	M	U
N	N	L	Y	D	H	Z	H	R	B	N
D	L	X	C	D	E	F	L	J	R	C
M	O	T	H	E	R	G	C	Y	O	L
O	M	N	B	T	N	J	O	P	T	E
T	A	B	M	S	W	N	U	Z	H	O
H	Q	R	W	N	U	N	S	X	E	Y
E	V	M	D	M	A	H	I	T	R	P
R	X	Y	Z	Q	A	U	N	T	L	R

ZONAL INSTITUTE OF EDUCATION & TRAINING, CHANDIGARH

Class: III

Sub: EVS

CLASS: III

TOPIC: OUR FIRST SCHOOL

DATE:

WRITE THE RELATION BETWEEN THE MEMBERS OF THE FAMILY:

Write the name of your family members in this house

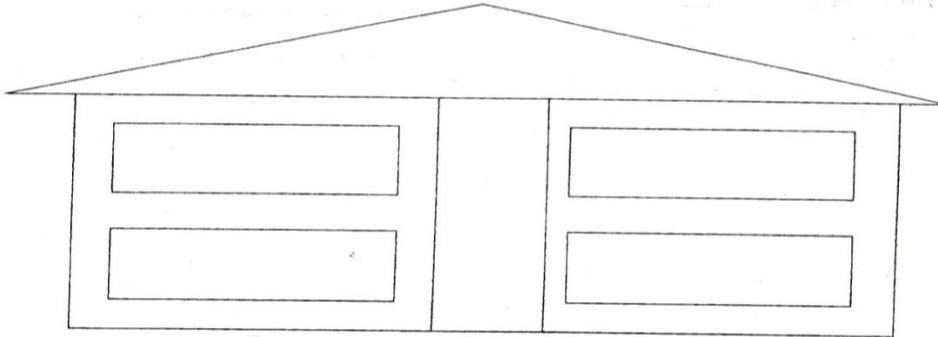

Write the relationship between the members of the family.



Names of the family members	Their relationship

CLASS: III

TOPIC : CHHOTU'S HOUSE

DATE :

Match the following to the pictures:

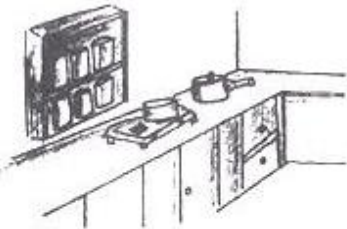

bathroom

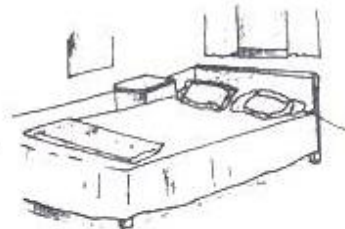

dining-room

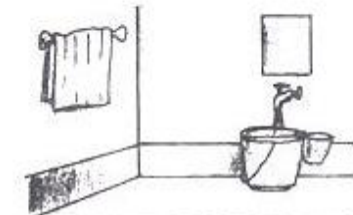

bedroom

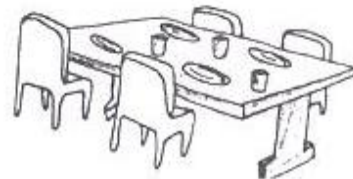

kitchen



Help Chhotu to find his house

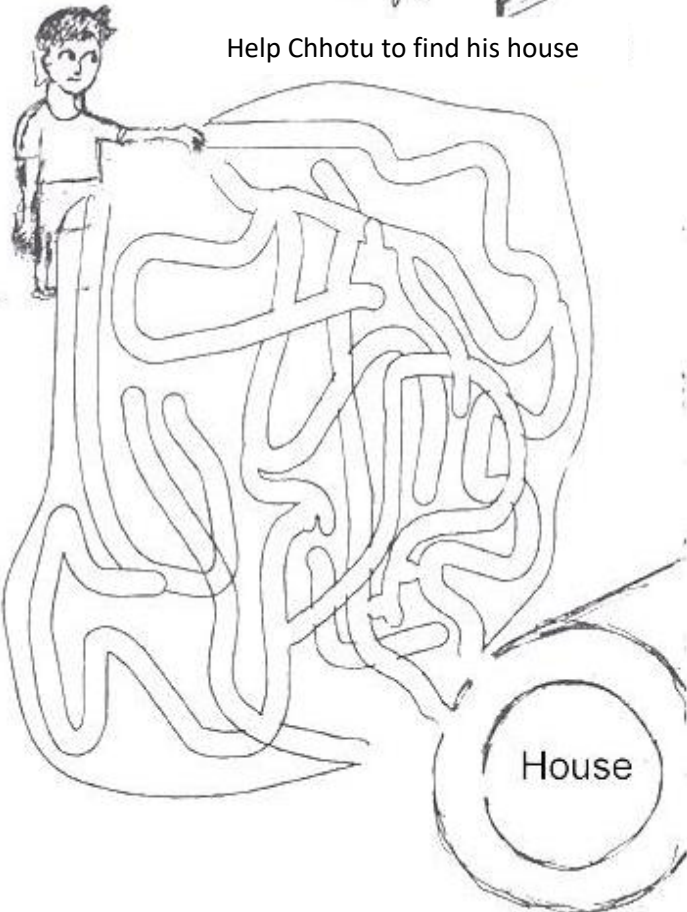

In which part of the house do you:

Sleep _____

Make food _____

Receive guest _____

Eat _____

CLASS : III

TOPIC : SAYING WITHOUT SPEAKING

DATE :

Match the following by drawing lines

- | | |
|------------|-----------------|
| (a) Eye | taste |
| (b) Nose | smell |
| (c) Ear | vision |
| (d) Tongue | feeling / touch |
| (e) Skin | hearing |

**Write the number in the box
1-eyes, 2-ears, 3-nose, 4-skin, 5-tongue**

Which sense organ is in use?

There is a gas leak in the kitchen.

Neem leaf is bitter.

Koko has soft hair.

The moon and the stars are in the sky.

The door bell rings.

ZONAL INSTITUTE OF EDUCATION & TRAINING, CHANDIGARH

Class: III

Sub: EVS

CLASS: III

TOPIC: SAYING WITHOUT SPEAKING

DATE:

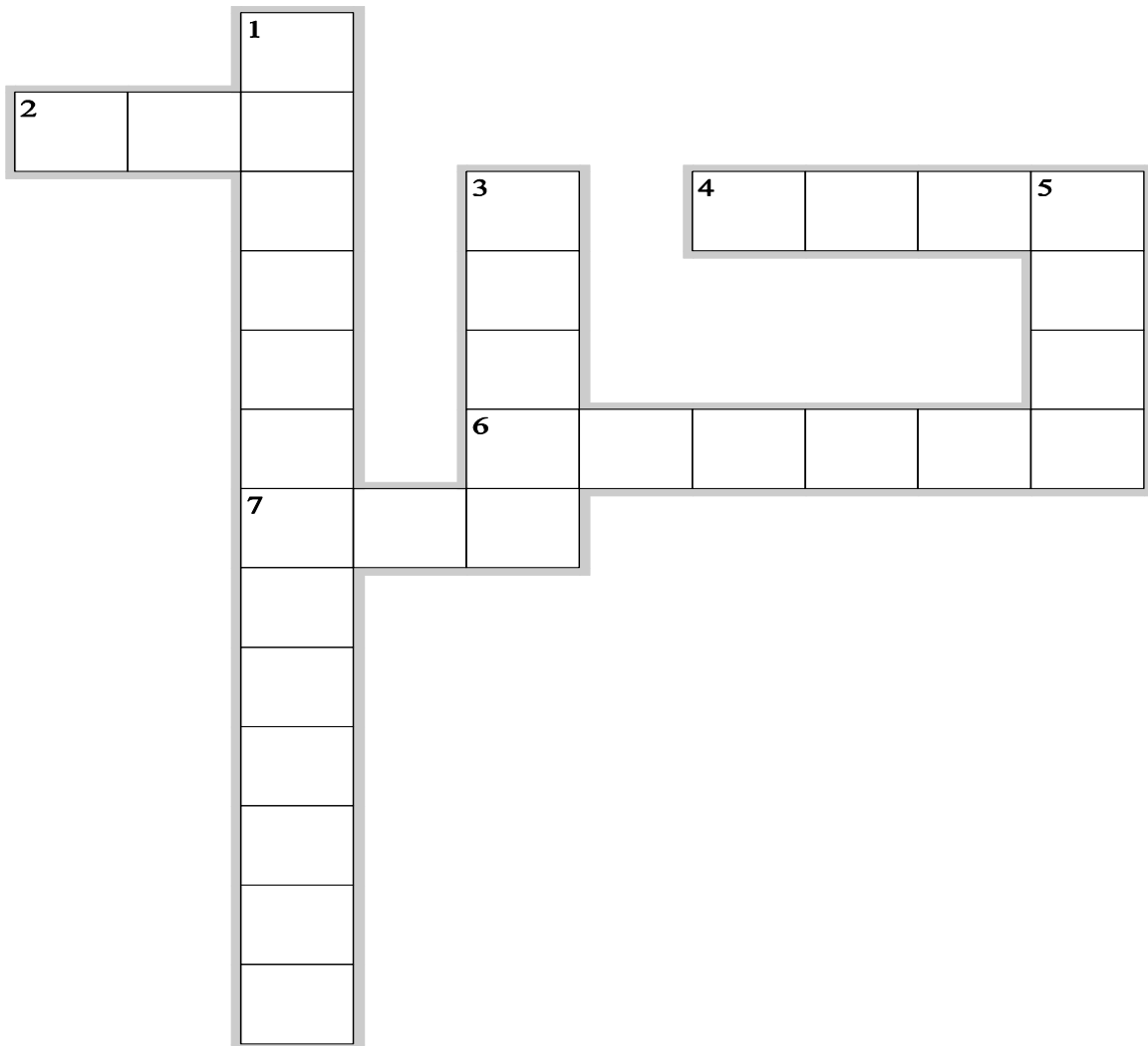

Across

- 2. HEARING
- 4. FEELING / TOUCH
- 6. TASTE
- 7. VISION

Down

- 1. SCRIPT USED BY BLIND PERSONS
- 3. TONGUE IS USED FOR
- 5. SMELL

ZONAL INSTITUTE OF EDUCATION & TRAINING, CHANDIGARH

Class: III

Sub: EVS

CLASS : III

TOPIC : FLYING HIGH

DATE :

Look at the beaks and name the bird.



Name the bird and label the parts.

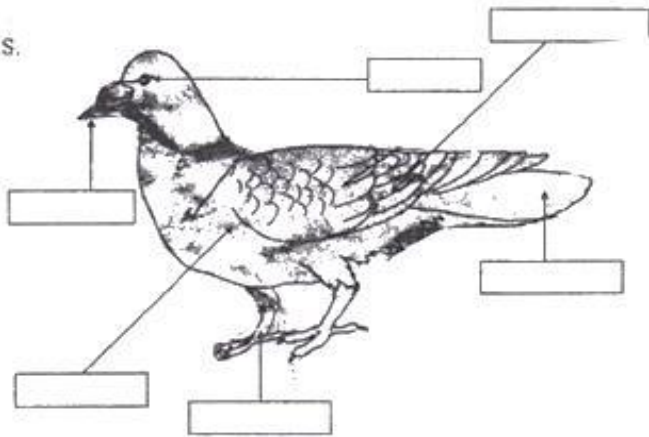

Where can you see the following birds ?



ZONAL INSTITUTE OF EDUCATION & TRAINING, CHANDIGARH

Class: III

Sub: EVS

CLASS: III

TOPIC : FLYING HIGH

DATE :

TICK THE CORRECT ANSWER:

1. The bird which stitches nest with leaves, thread etc.

- a. crow b. owl c. tailor bird d. weaver bird

2. The lazy bird lays its eggs in an another bird's nest.

- a. Crow b. Cuckoo c. Duck d. Eagle

3. They are the smallest birds. They can fly backwards too.

- a. Parrot b. Albatross c. Bulbul d. Hummingbird

4. The national bird of India.

- a. Pigeon b. Peacock c. Goose d. Hen

5. The flightless bird of New Zealand.

- a. Owl b. swan c. Nightingale d. Kiwi

6. The bird with a sharp beak to make holes on the barks of the trees.

- a. Woodpecker b. Vulture c. Jay d. Penguin

7. The largest and the heaviest bird.

- a. Robin b. Sparrow c. Ostrich d. Quail

8. The bird which has a webbed feet.

- a. Chick b. Duck c. Kite d. Lovebird

9. They eat up dead animals and thus are called 'scavengers'.

- a. Vulture b. Cock c. Myna d. Swan

10. They are pink birds with long legs.

- a. Eagle b. Flamingo c. Umbrella bird d. Dove

CLASS: III

TOPIC: FLYING HIGH

DATE:

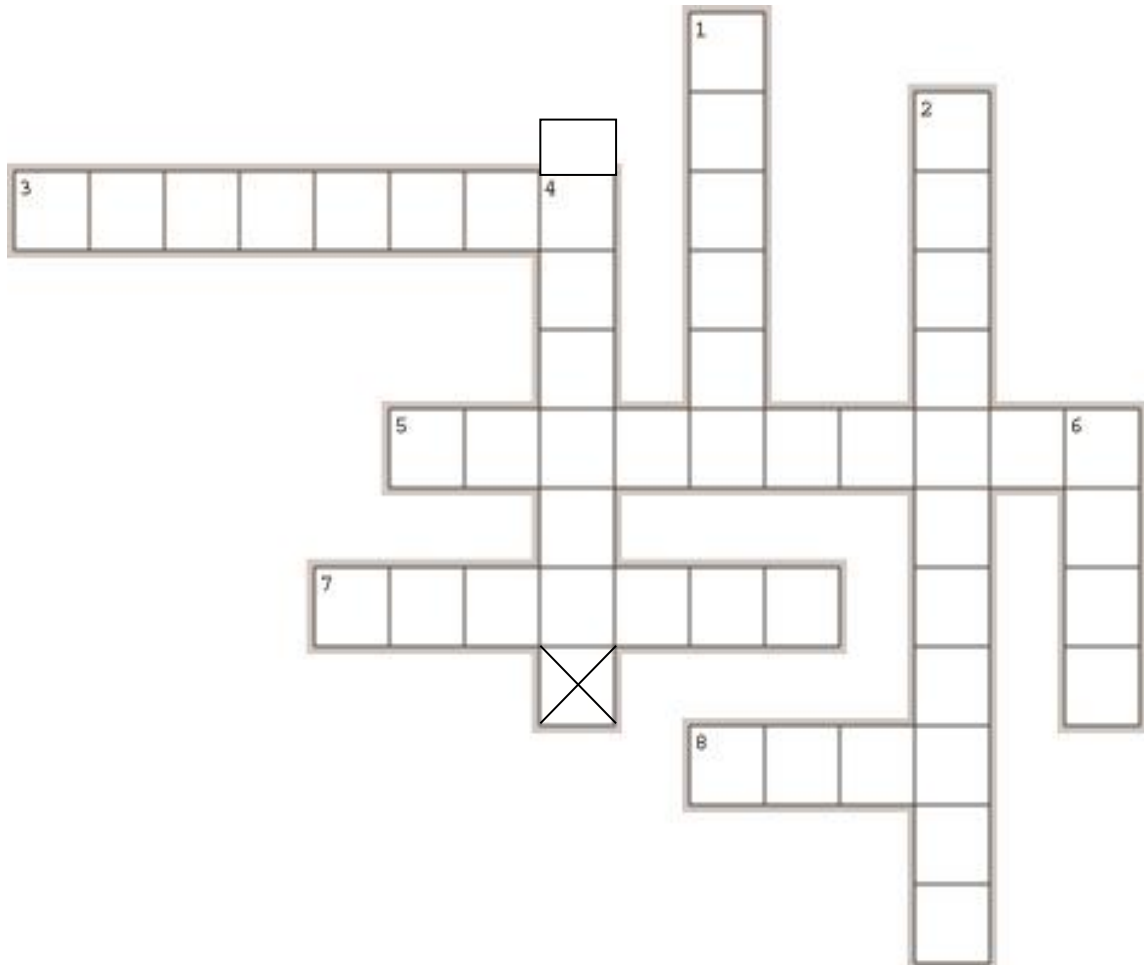

Across

3. THEY ARE PINK BIRDS WITH LONG LEGS
5. THE BIRD WHICH STITCHES NEST WITH LEAVES, THREAD ETC.
7. THE NATIONAL BIRD OF INDIA
8. THE FLIGHTLESS BIRD OF NEW ZEALAND

Down

1. THE LAZY BIRD WHICH LAYS EGGS IN ANOTHER BIRD'S NEST.
2. THEY ARE THE SMALLEST BIRDS. THEY CAN FLY BACKWARDS TOO.
4. THE LARGEST AND HEAVIEST BIRD.
6. BIRD WITH WEBBED FEET.

CLASS:III TOPIC:IT'S RAINING

DATE:

Label the Water Cycle.

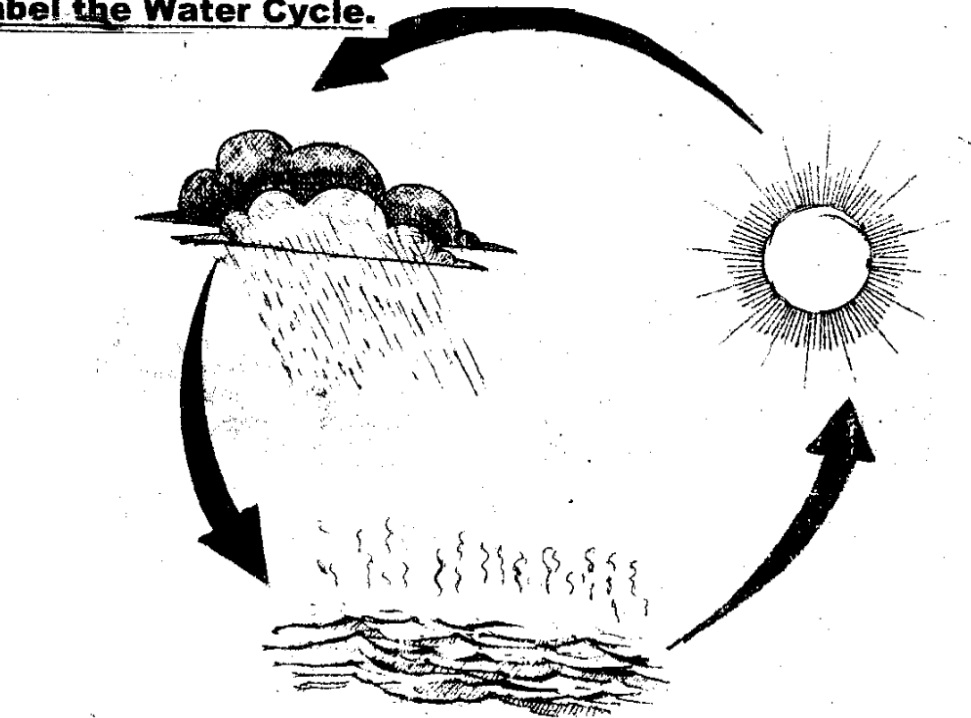

Name the five things which we see on a rainy day.

1. _____

2. _____

3. _____

4. _____

5. _____

ZONAL INSTITUTE OF EDUCATION & TRAINING, CHANDIGARH

Class: III

Sub: EVS

CLASS:III TOPIC: IT'S RAINING

DATE:

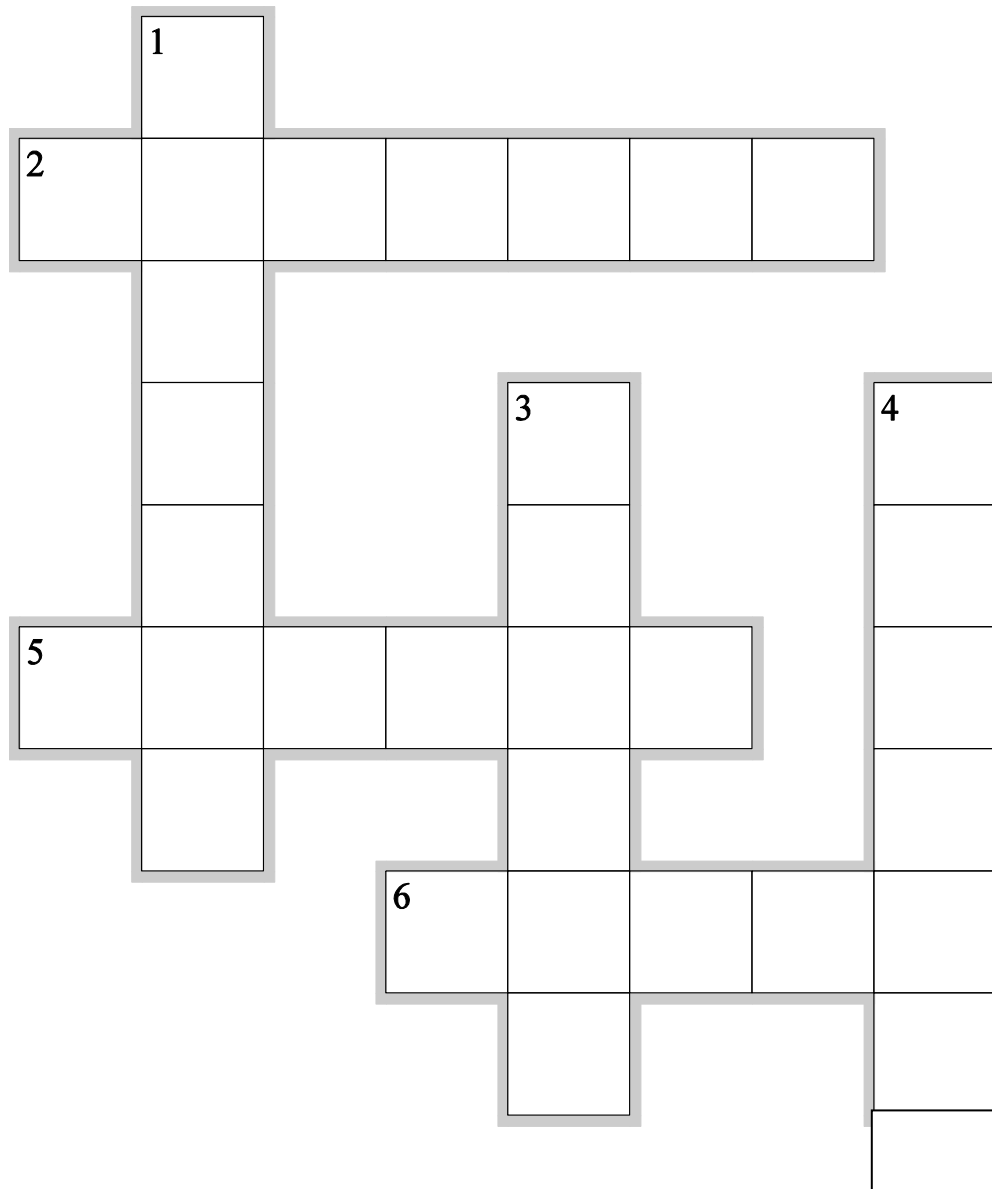

Across

2. RIVER ALSO KNOWN AS SOUTHERN GANGA
5. TAJ MAHAL IS SITUATED ON THE BANK OF WHICH RIVER
6. THE LONGEST RIVER OF THE INDIA

Down

1. RIVER KNOWN AS BANGAL'S SORROW
3. STATE NAMED UPON THE FIVE STATES
4. TAPTI RIVER FLOWS IN WHICH STATE

ZONAL INSTITUTE OF EDUCATION & TRAINING, CHANDIGARH

Class: III

Sub: EVS

CLASS : III

TOPIC : WHAT IS COOKING

DATE :

Write the name of the Utensils

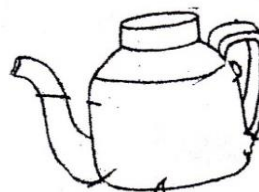
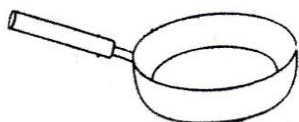
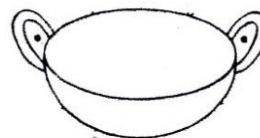
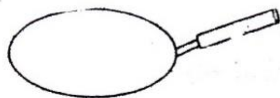
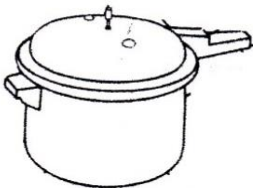

Write the name of the applications and the fuel used in it .





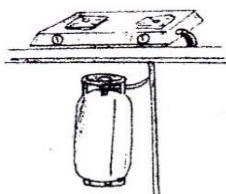







Encircle the odd one :

Aluminium, iron , Stainless steel, cow dung cake, clay , copper ,
air , brass, Kerosene

ZONAL INSTITUTE OF EDUCATION & TRAINING, CHANDIGARH

Class: III

Sub: EVS

CLASS: III

TOPIC: WHAT IS COOKING?

DATE:

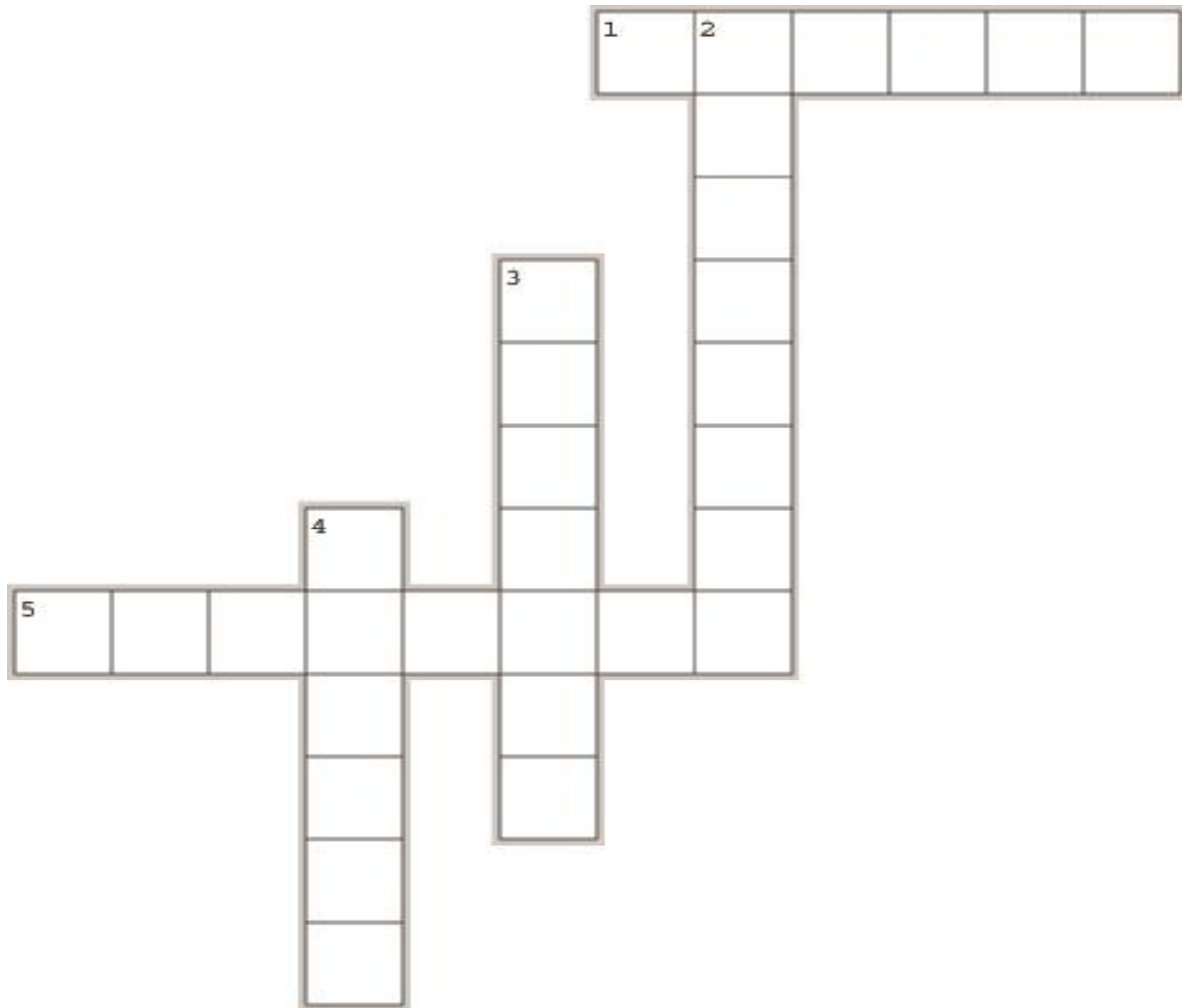

Across

1. METHOD USED FOR COOKING NOODLES
5. METHOD USED FOR MAKING IDLI

Down

2. METHOD USED FOR MAKING BREAD
3. METOD USED FOR COOKING EGG
4. METHOD USED FOR MAKING CAKE

ZONAL INSTITUTE OF EDUCATION & TRAINING, CHANDIGARH

Class: III

Sub: EVS

CLASS: III

TOPIC: FROM HERE TO THERE

DATE:

MATCH THE FOLLOWING:

- | | | |
|--------------|----|-----------------|
| 1. TRUCK | -- | FOUR WHEELER |
| 2. AEROPLANE | -- | WATER TRANSPORT |
| 3. BOAT | -- | AIR TRANSPORT |
| 4. CAR | -- | ROAD TRANSPORT |

Name four means of each:

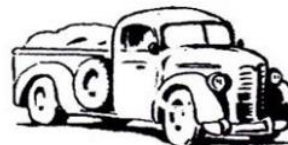
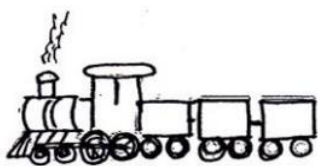

1. Land Transport

a) _____

b) _____

c) _____

d) _____

2. Water Transport

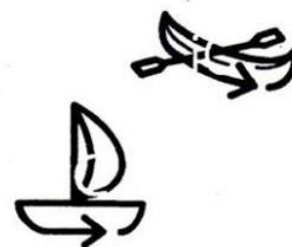

a) _____

b) _____

b) _____

c) _____

ZONAL INSTITUTE OF EDUCATION & TRAINING, CHANDIGARH

Class: III

Sub: EVS

CLASS:III

TOPIC: FROM HERE TO THERE

DATE:

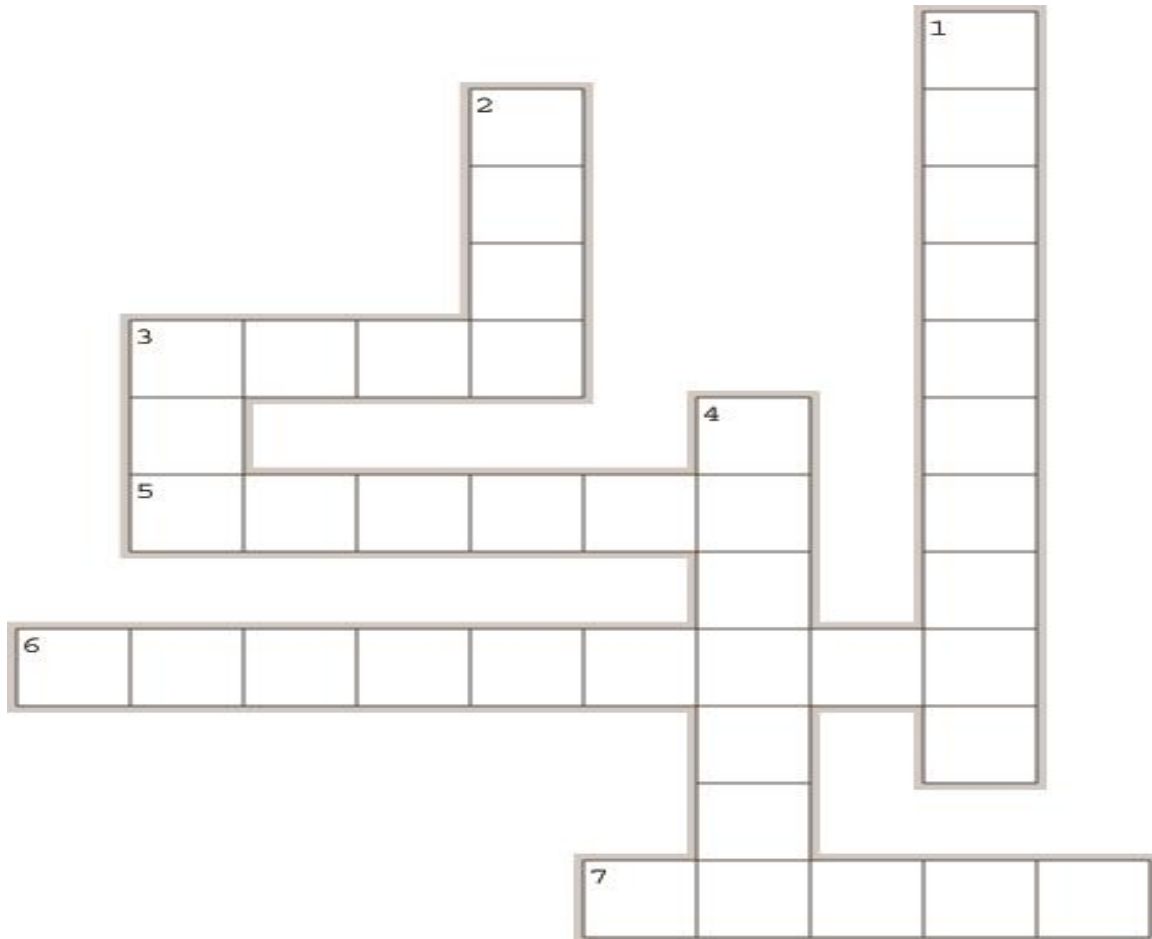

Across

3. CAN BE PULLED BY A HORSE AND BULLOCK
5. FLIES VERY FAST
6. CARRIES PASSENGERS IN THE AIR
7. RUNS ON TRACK

Down

1. AIRCRAFT WITHOUT WINGS AND LIFT FROM THE ROTATION OF OVERHEAD BLADES
2. SAILS ON WATER
3. RUNS ON ROAD
4. CARRIES PASSENGERS AND GOODS ON WATER

ZONAL INSTITUTE OF EDUCATION & TRAINING, CHANDIGARH

Class: III

Sub: EVS

CLASS: III

TOPIC: WORK WE DO

DATE:

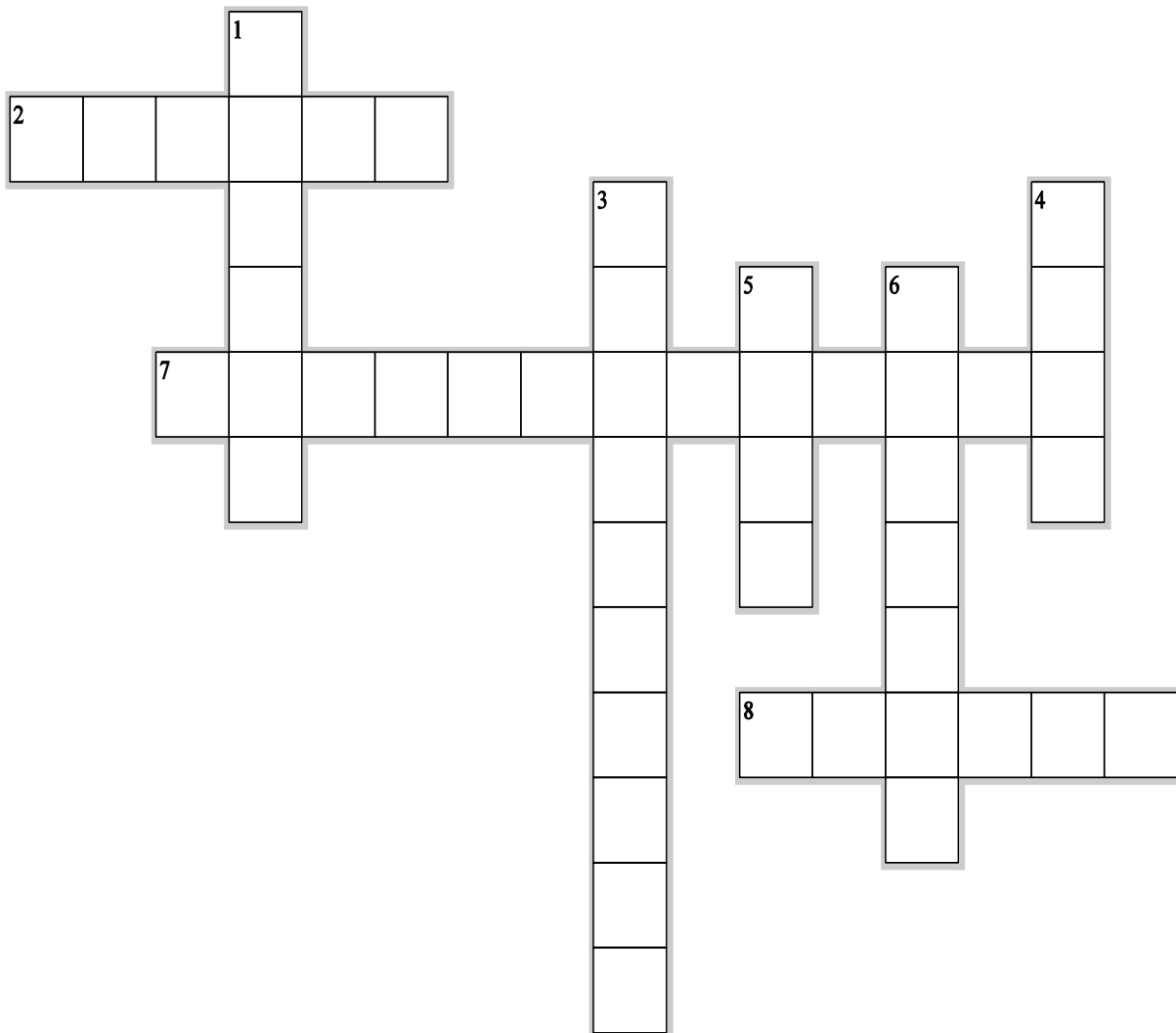

Across

- 2. A PLACE TO STUDY
- 7. THIEVES ARE TAKEN THERE
- 8. MANY SHOPS

Down

- 1. SICK PEOPLE GO THERE
- 3. A PLACE WHERE WE CAN BUY STAMPS
- 4. PEOPLE KEEP MONEY
- 5. A PLACE FOR WALKING AND PLAYING
- 6. BORROWING BOOKS

ZONAL INSTITUTE OF EDUCATION & TRAINING, CHANDIGARH

Class: III

Sub: EVS

CLASS : III

TOPIC:SHARING OUR FEELINGS

DATE:



Who invented Braille Script?

What is meant by Braille Script ?

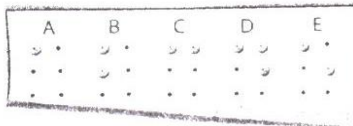

How do blind people read the Braille Script?



MATCH THE FOLLOWING
COLUMN A

COLUMN B

- 1 A person who cannot speak
- 2 A person who cannot hear
- 3 A person who cannot walk
- 4 A person who cannot see

- blind
- lame
- deaf
- dumb

ZONAL INSTITUTE OF EDUCATION & TRAINING, CHANDIGARH

Class: III

Sub: EVS

CLASS: III

TOPIC: SHARING OUR FEELINGS

DATE:

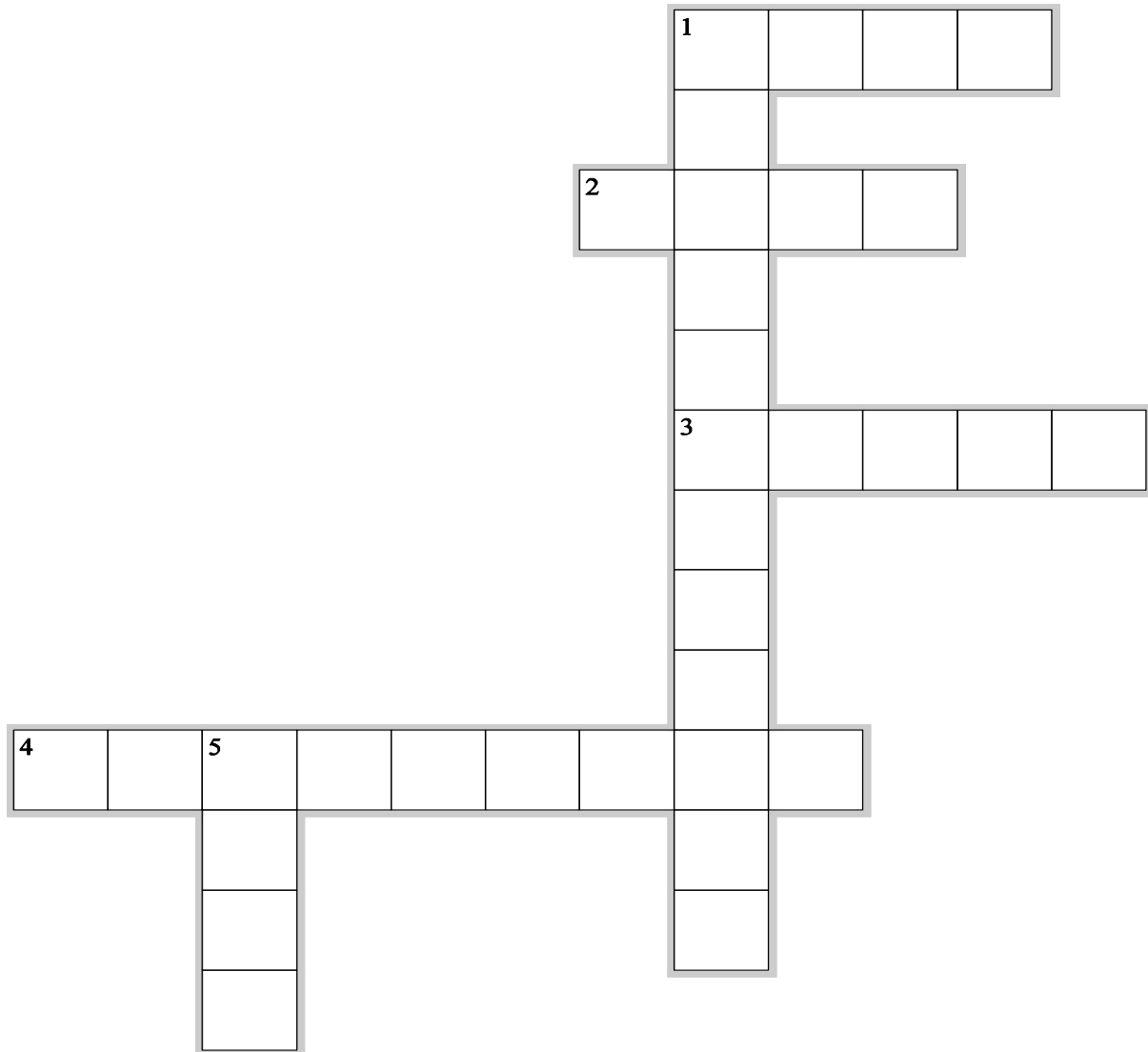

Across

1. A PERSON WHO CANNOT WALK
2. A PERSON WHO CANNOT SPEAK
3. A PERSON WHO CANNOT SEE
4. THEY CANNOT RUN FAST

Down

1. BRAILLE SCRIPT IS INVENTED BY
5. A PERSON WHO CANNOT HEAR

ZONAL INSTITUTE OF EDUCATION & TRAINING, CHANDIGARH

Class: III

Sub: EVS

CLASS : III

TOPIC : THE STORY OF FOOD

DATE :

Write the names of the following and which parts of the plant is used as food.

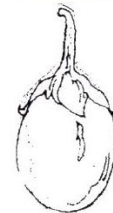
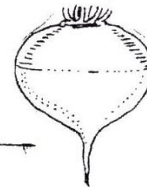
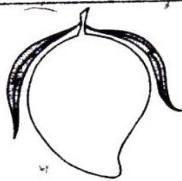
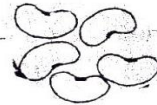
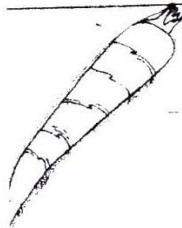
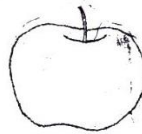
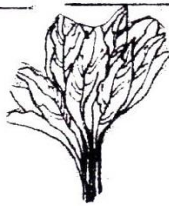
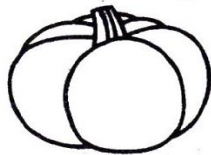

Name the following.

a) A vegetable that is a flower. _____

b) A fruit that has the same name as a colour. _____

c) Our national fruit. _____

d) A fruit that keeps the doctor away. _____

ZONAL INSTITUTE OF EDUCATION & TRAINING, CHANDIGARH

Class: III

Sub: EVS

CLASS: III

TOPIC: THE STORY OF FOOD

DATE:

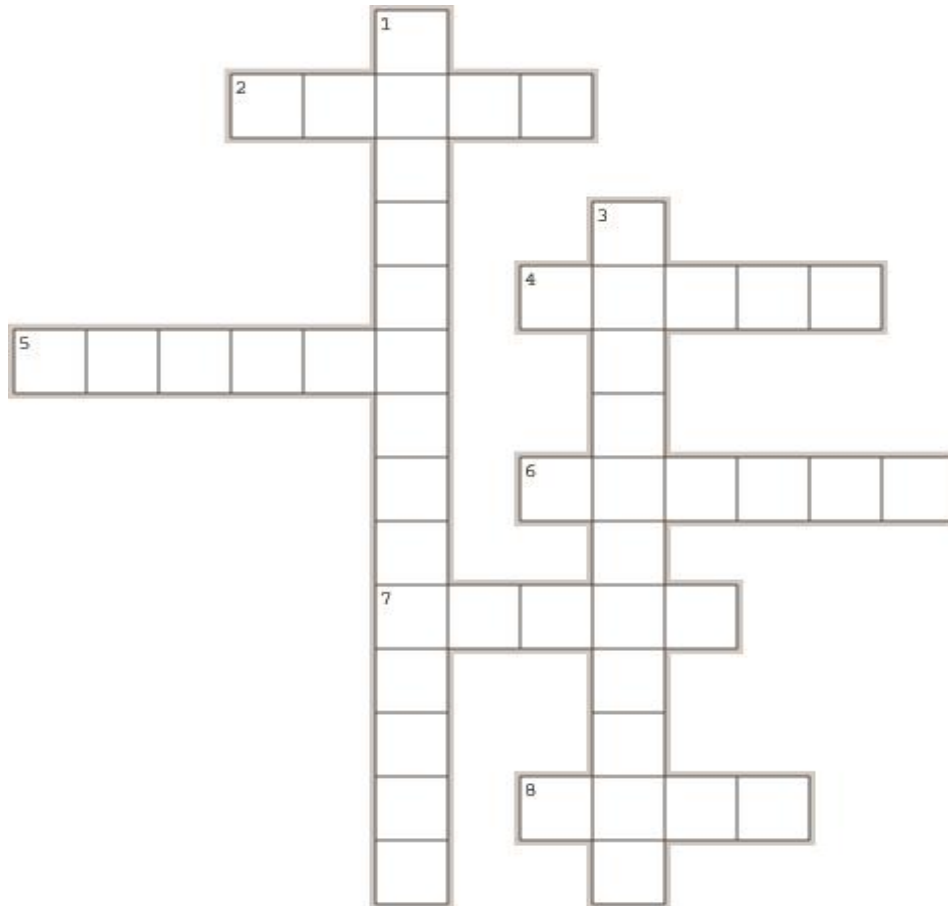

Across

2. MEDICINAL PLANT USED IN TOOTHACHE
4. OUR NATIONAL FRUIT
5. A FRUIT THAT HAS THE SAME NAME AS COLOUR
6. MEDICINAL PLANT USED FOR COUGH AND COLD
7. A FRUIT THAT KEEPS THE DOCTOR AWAY
8. CABBAGE IS A

Down

1. CARROT AND RADISH ARE
3. A VEGETABLE THAT IS A FLOWER

ZONAL INSTITUTE OF EDUCATION & TRAINING, CHANDIGARH

Class: III

Sub: EVS

CLASS : III

TOPIC : MAKING POTS

DATE :

Observe and write the story of making clay pot :



Some clay pots are shown below. Find out their name and write.

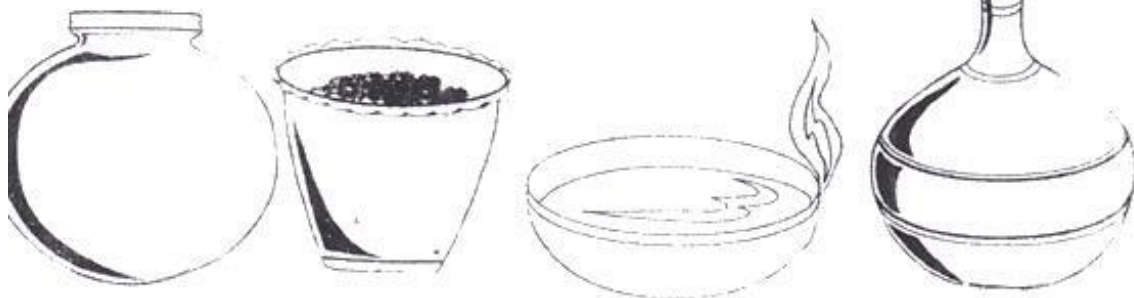

ZONAL INSTITUTE OF EDUCATION & TRAINING, CHANDIGARH

Class: III

Sub: EVS

CLASS : III

TOPIC: GAMES WE PLAY

DATE:

Name the things that needed to play.

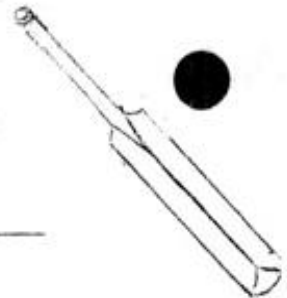

Help Raju to reach the ball.

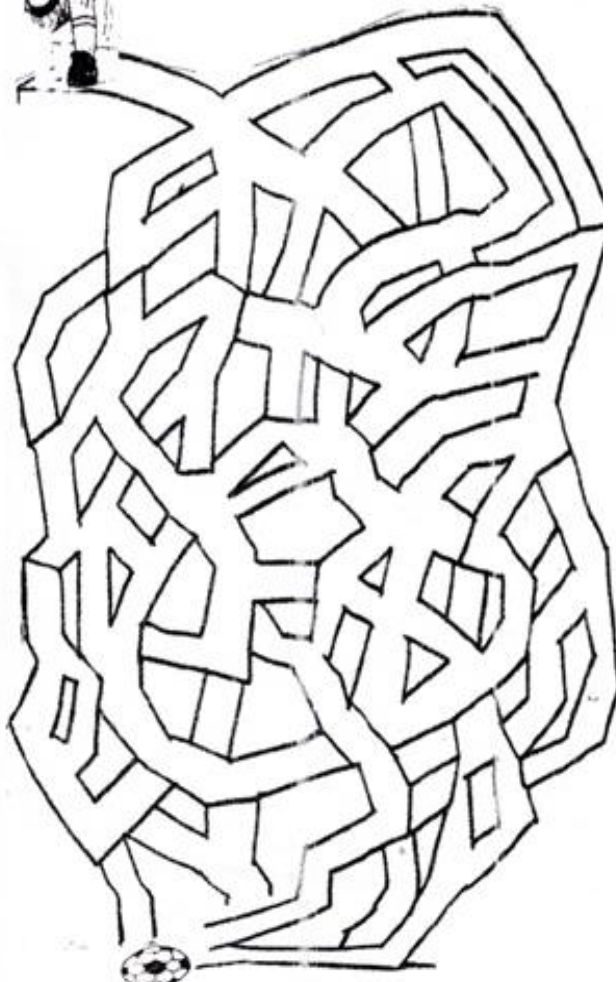

Write the name of the game that the following sports person associated with:

SACHIN TENDULKAR _____

SANIA MIRZA _____

VISWANATH ANAND _____

DHANRAJ PILLAI _____

LEANDER PEAS _____

ZONAL INSTITUTE OF EDUCATION & TRAINING, CHANDIGARH

Class: III

Sub: EVS

CLASS: III

TOPIC: GAMES WE PLAY

DATE:

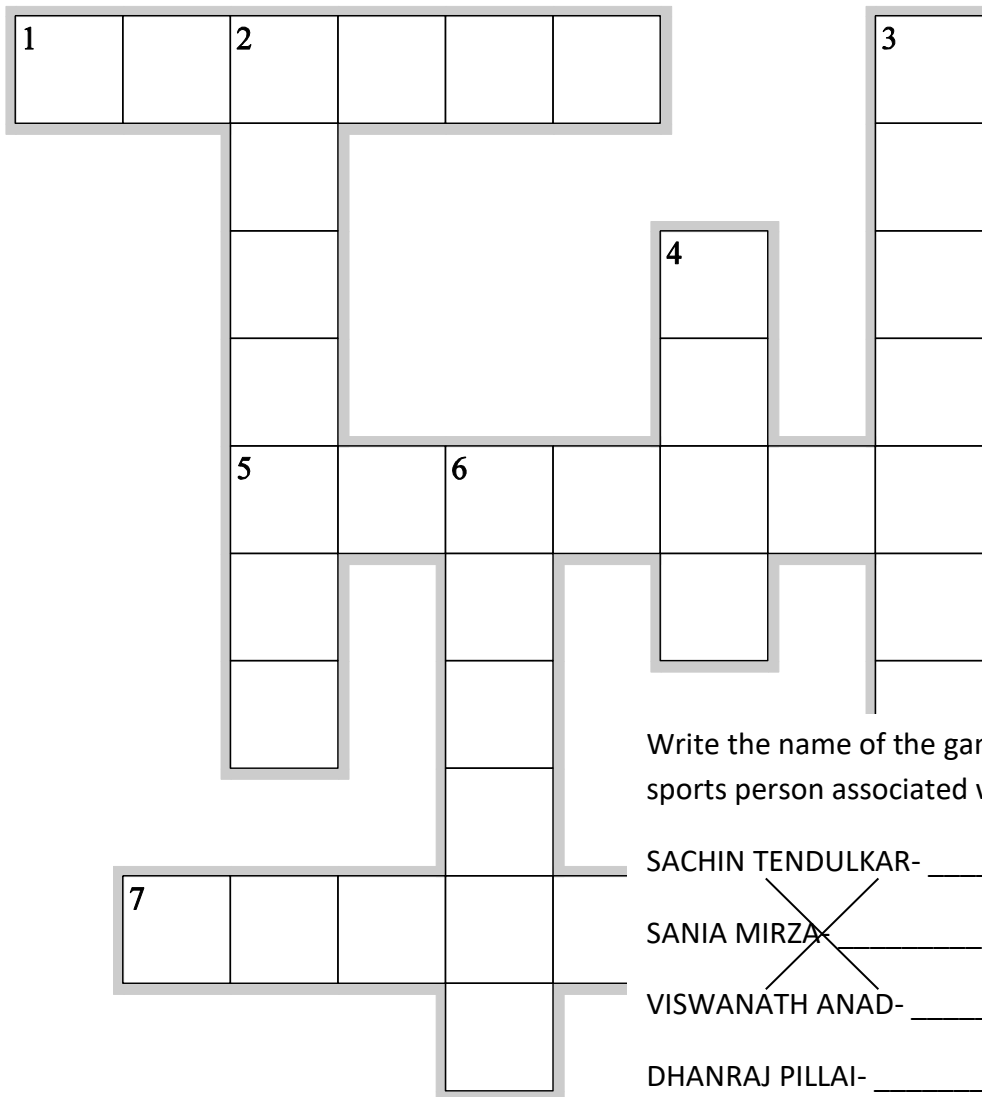

Write the name of the game that the following sports person associated with.

SACHIN TENDULKAR- _____

SANIA MIRZA- _____

VISWANATH ANAD- _____

DHANRAJ PILLAI- _____

LEANDER PEAS- _____

Across

1. DHANRAJ PILLAI IS ASSOCIATED WITH
5. SIX PLAYERS IN A TEAM
7. NAME THE GAME THAT SANIA MIRZA IS REI

Down

2. TEAM CONSITS OF 11 PLAYERS
3. GAME PLAYED BY SHUTTLE COCK
4. DICE IS RELATED TO
6. MARRYKOM IS RELATED TO

ZONAL INSTITUTE OF EDUCATION & TRAINING, CHANDIGARH

Class: III

Sub: EVS

CLASS : III

TOPIC : HERE COMES A LETTER

DATE :

WRITE YOUR HOUSE ADDRESS

COLOUR THE POST BOX

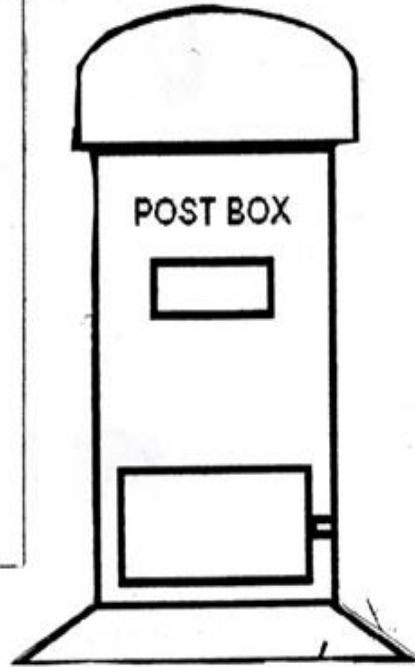
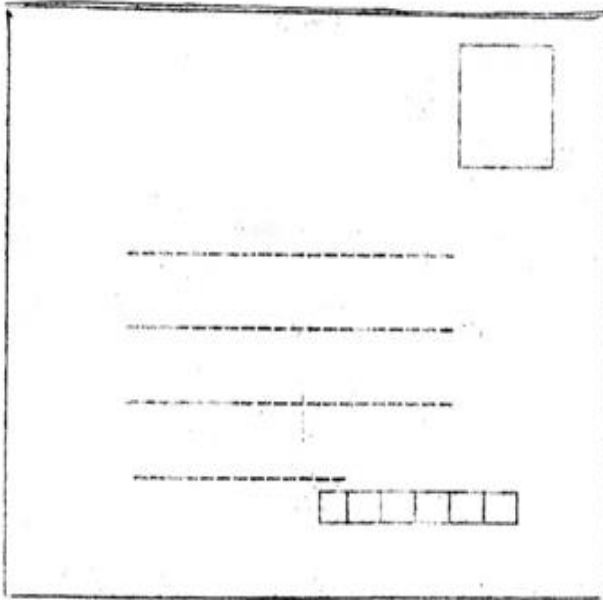

Help Ramu to post the letter:

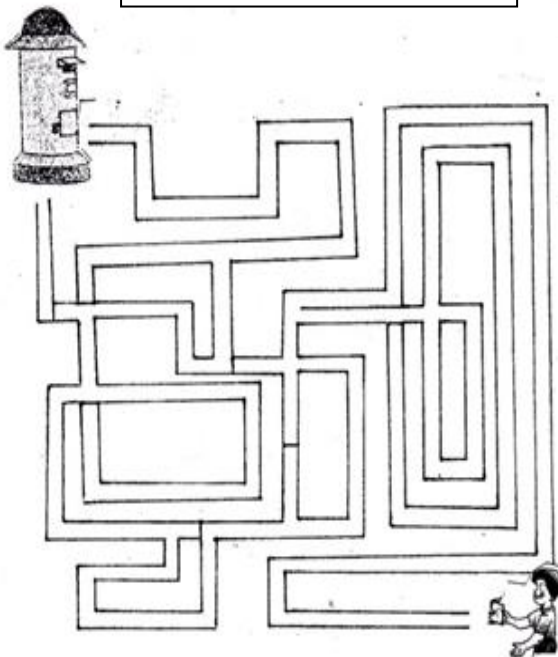

Write two lines about the postman



ZONAL INSTITUTE OF EDUCATION & TRAINING, CHANDIGARH

Class: III

Sub: EVS

CLASS: III

TOPIC: HERE COMES A LETTER

DATE:

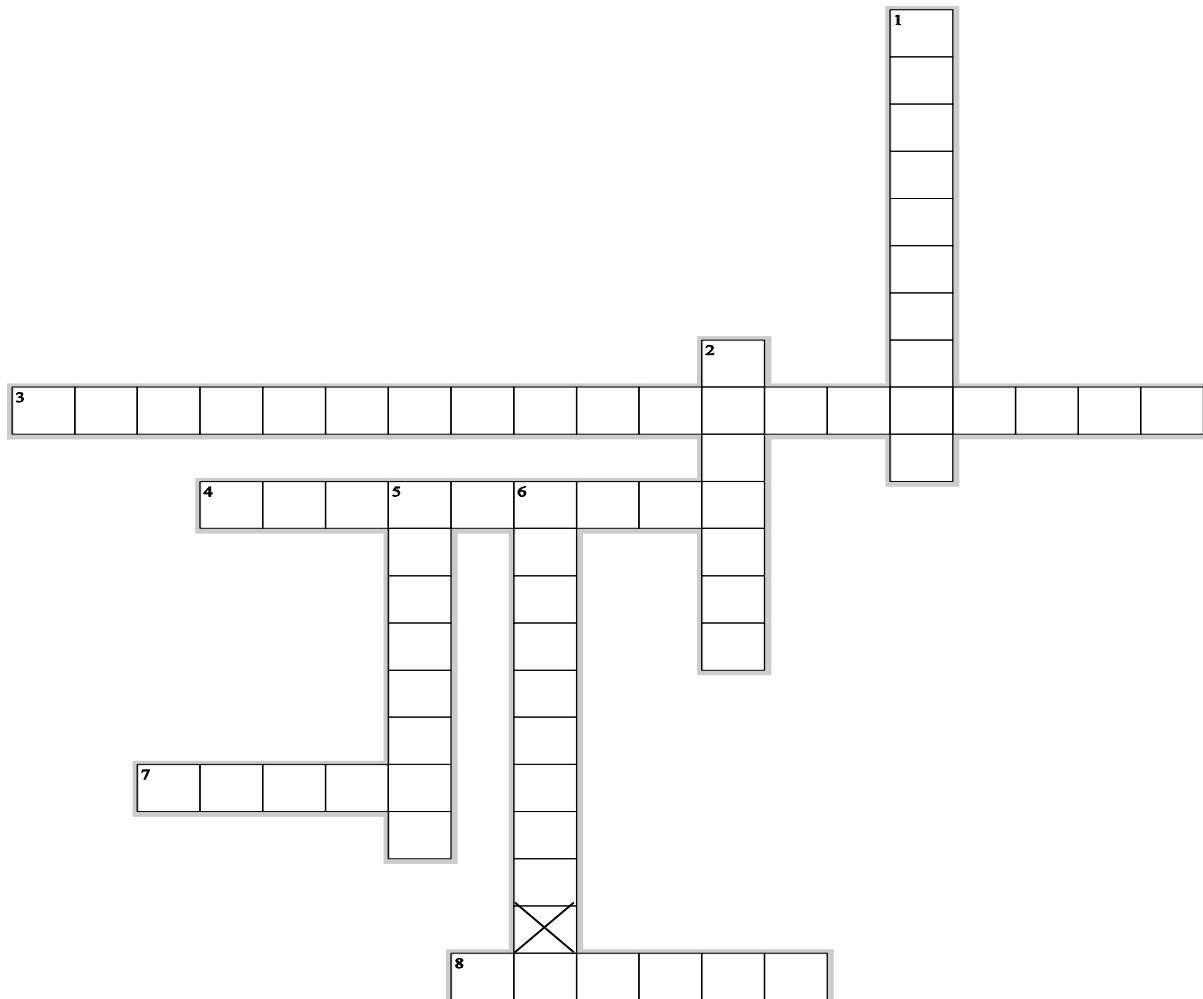

Across

3. MOBILE PHONE IS A
4. LETTER CAN BE DELIVERED IN ONE OR TWO DAYS
7. AFFIXED IT ON PARCEL
8. POSTMAN DELIVERS

Down

1. MONEY IS SEND BY IT
2. WE POST OUR LETTER IN IT
5. LETTER IS PUT IN IT TO BE POSTED
6. A PLACE WHERE WE CAN BUY INLAND LETTERS

CLASS : III

TOPIC : A HOUSE LIKE THIS

DATE :

Name the house and place where they are built.



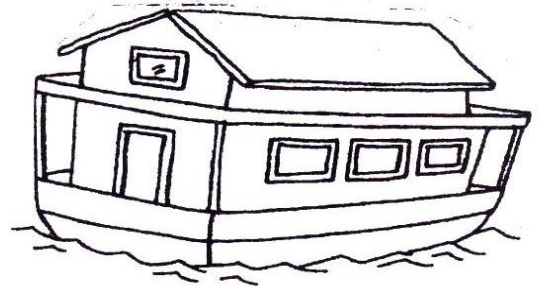

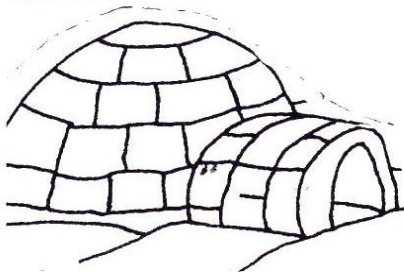



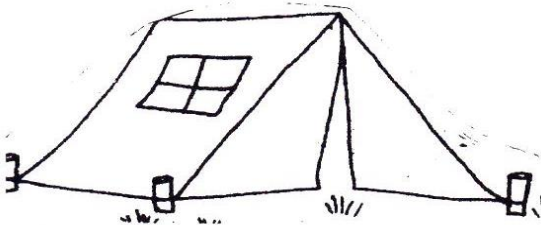

ZONAL INSTITUTE OF EDUCATION & TRAINING, CHANDIGARH

Class: III

Sub: EVS

CLASS: III

TOPIC: A HOUSE LIKE THIS

DATE:

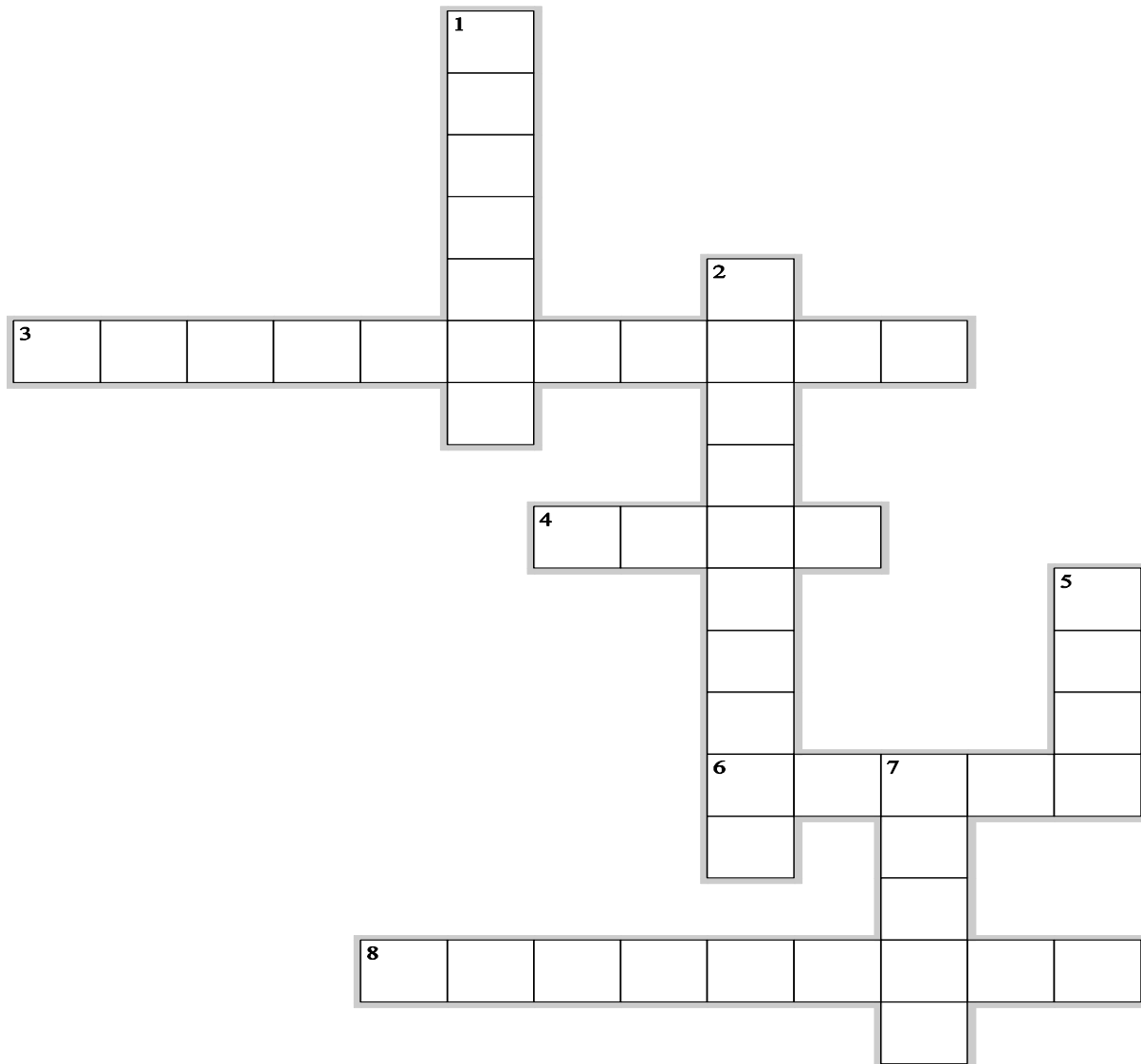

Across

- 3. HOUSE MADE OF MUD
- 4. A MULTISTOREYED HOUSE
- 6. A HOUSE ON BAMBOO PILLARS
- 8. FOUND IN KASHMIR

Down

- 1. A HOUSE ON WHEELS
- 2. MADE OF CEMENT AND STONES
- 5. A TEMPORARY HOUSE
- 7. A HOUSE MADE OF SNOW

ZONAL INSTITUTE OF EDUCATION & TRAINING, CHANDIGARH

Class: III

Sub: EVS

CLASS : III

TOPIC : LEFT AND RIGHT

DATE :

Mark the following palms right and left.



Paint the horses going towards the right blue.

Paint the horses going towards the left red.

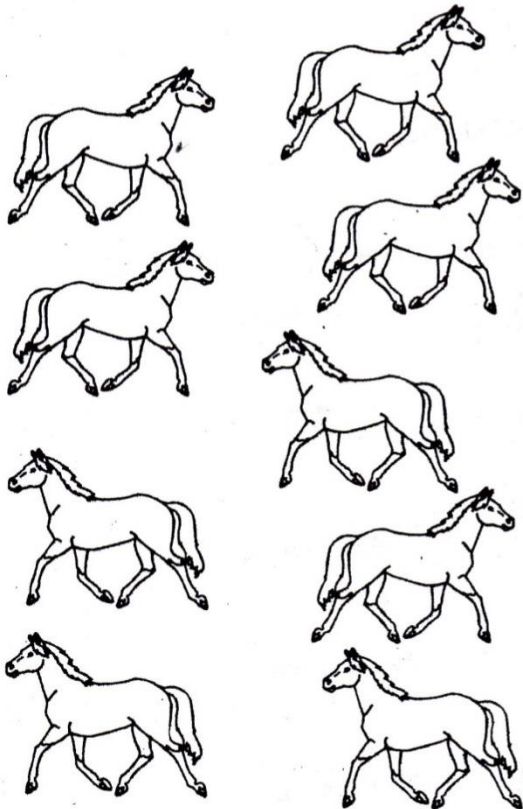

Write the symbols for the following .

Addition:

Subtraction:-

Multiplication:-

Division:-

Equal:-

Greater than:-

Less than:-

Percentage:-

River:-

Mountain:-

Road:-

Tree:-

ZONAL INSTITUTE OF EDUCATION & TRAINING, CHANDIGARH

Class: III

Sub: EVS

CLASS: III

TOPIC: LEFT AND RIGHT

DATE:

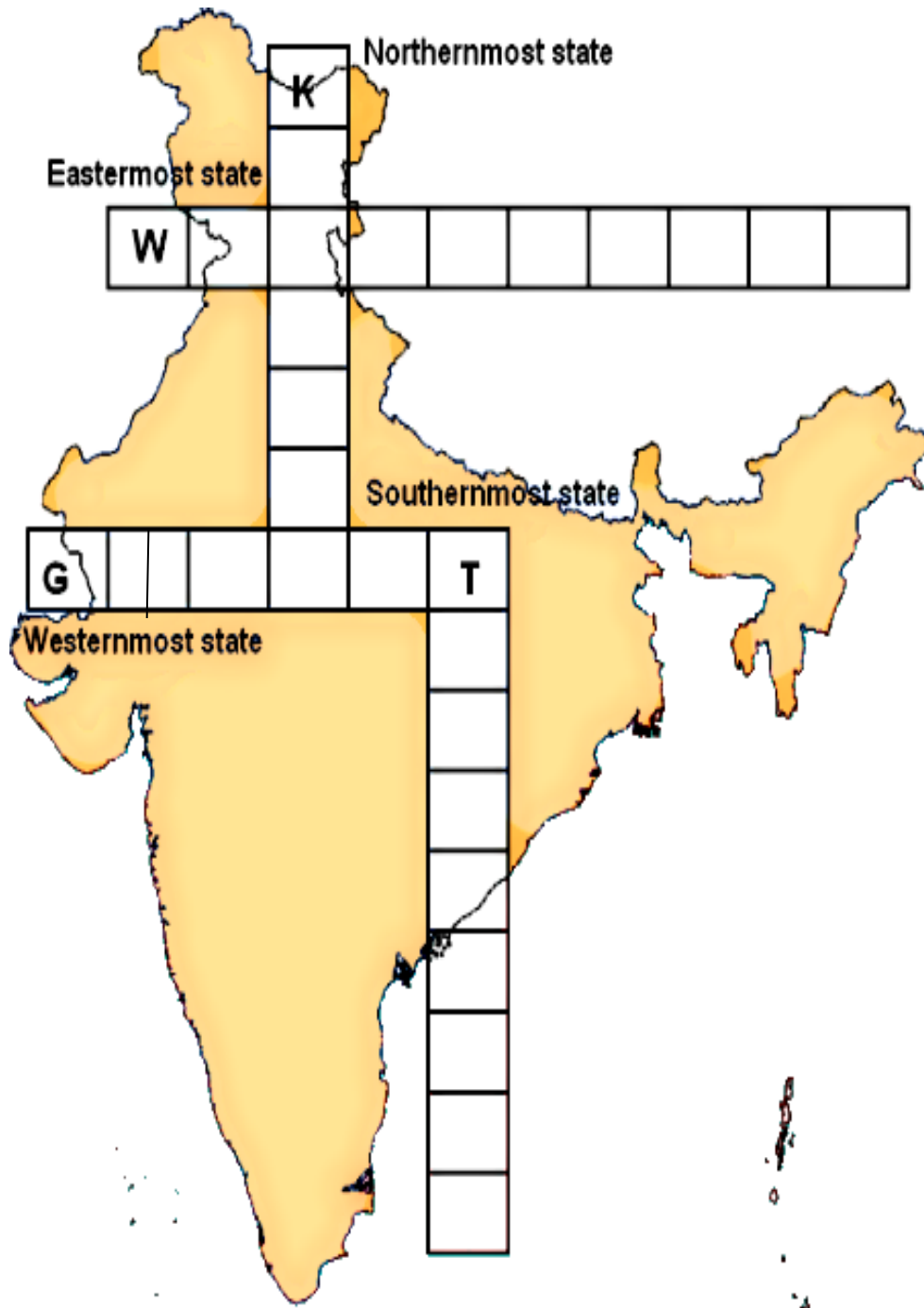

ZONAL INSTITUTE OF EDUCATION & TRAINING, CHANDIGARH

Class: III

Sub: EVS

CLASS : III

TOPIC: A BEAUTIFUL CLOTH

DATE :

1.Name the following.

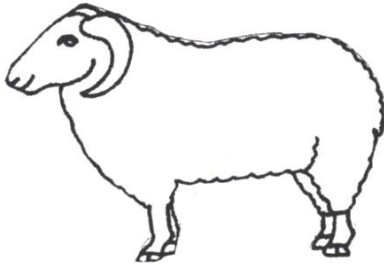

2.Arrange the following in correct order.

1) Dress, cotton plant, cotton cloth, cotton fibre, cotton seed.

2) silk worm, moth, eggs, silk thread, pupa, silk cloth

3) hair, sweater, sheep, wool

3.Who am I

This animal gives its wooly hair

Weaver makes wool out of it

We wear it to stay warm.

ZONAL INSTITUTE OF EDUCATION & TRAINING, CHANDIGARH

Class: III

Sub: EVS

CLASS: III

TOPIC: A BEAUTIFUL CLOTH

DATE:

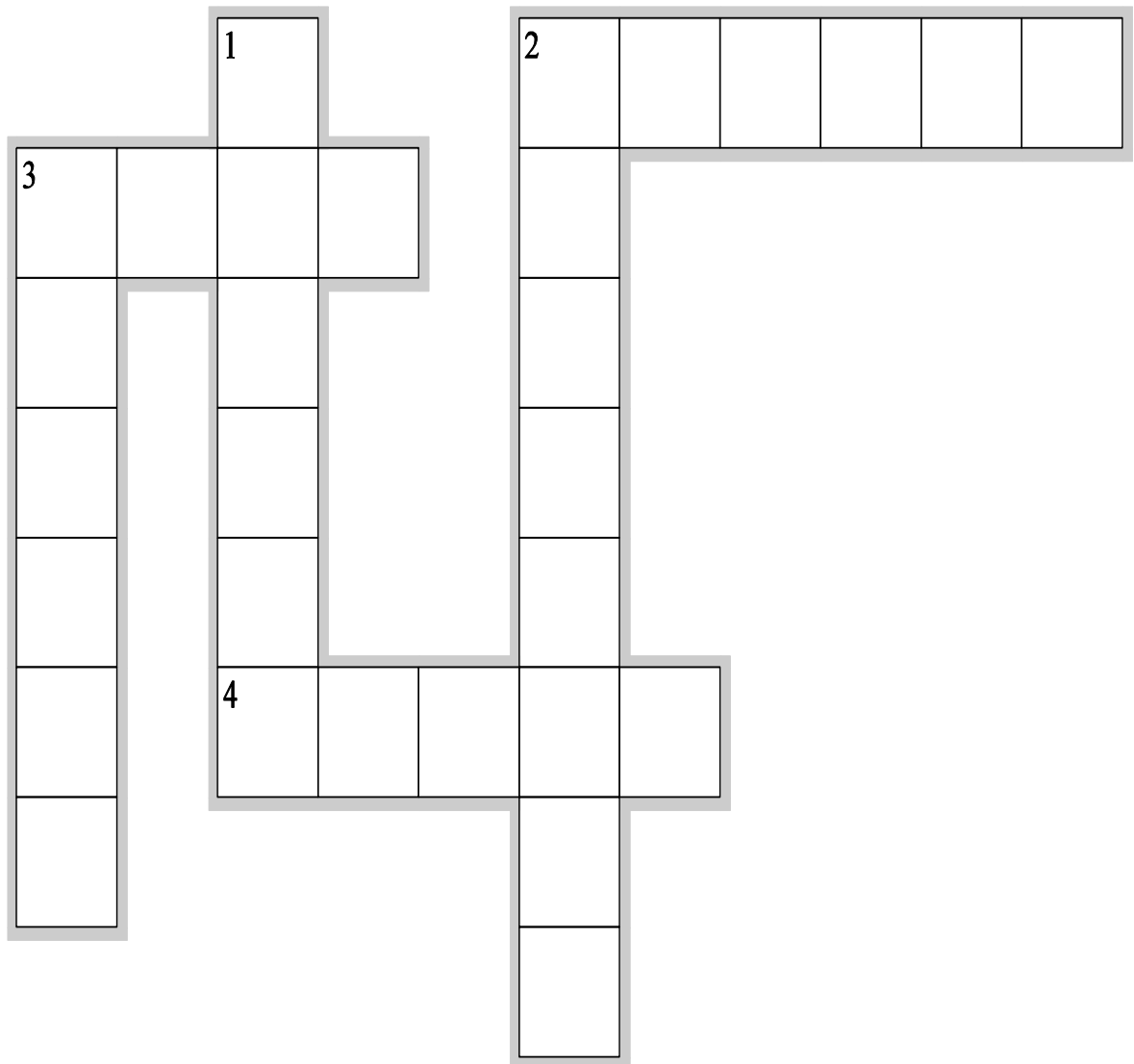

Across

2. COTTON CLOTH IS GOOD TO WEAR IN
3. SHIP GIVES US THIS
4. IT IS A SYNTHETIC CLOTH

Down

1. WE GET IT FROM A PLANT
2. WE GET SILK FROM
3. WOOLEN CLOTH IS GOOD TO WEAR IN

ZONAL INSTITUTE OF EDUCATION & TRAINING, CHANDIGARH

Class: III

Sub: EVS

CLASS : III

TOPIC : THE WEB OF LIFE

DATE :

1. Observe the following items given below and find out which ones are natural and which ones are man-made things :



NATURAL THINGS

MAN MADE THINGS

2. Name two things needed by a -

a) Man _____

b) Bird _____

c) Plant _____

d) Lion _____

कक्षा 3

पाठ -1 कककू

तारीख:

1. रेलगाड़ी के पहले डिब्बे में अपना नाम लिखकर बाकी डिब्बों में नामों की सीढ़ी बनाइए और लिखिये:

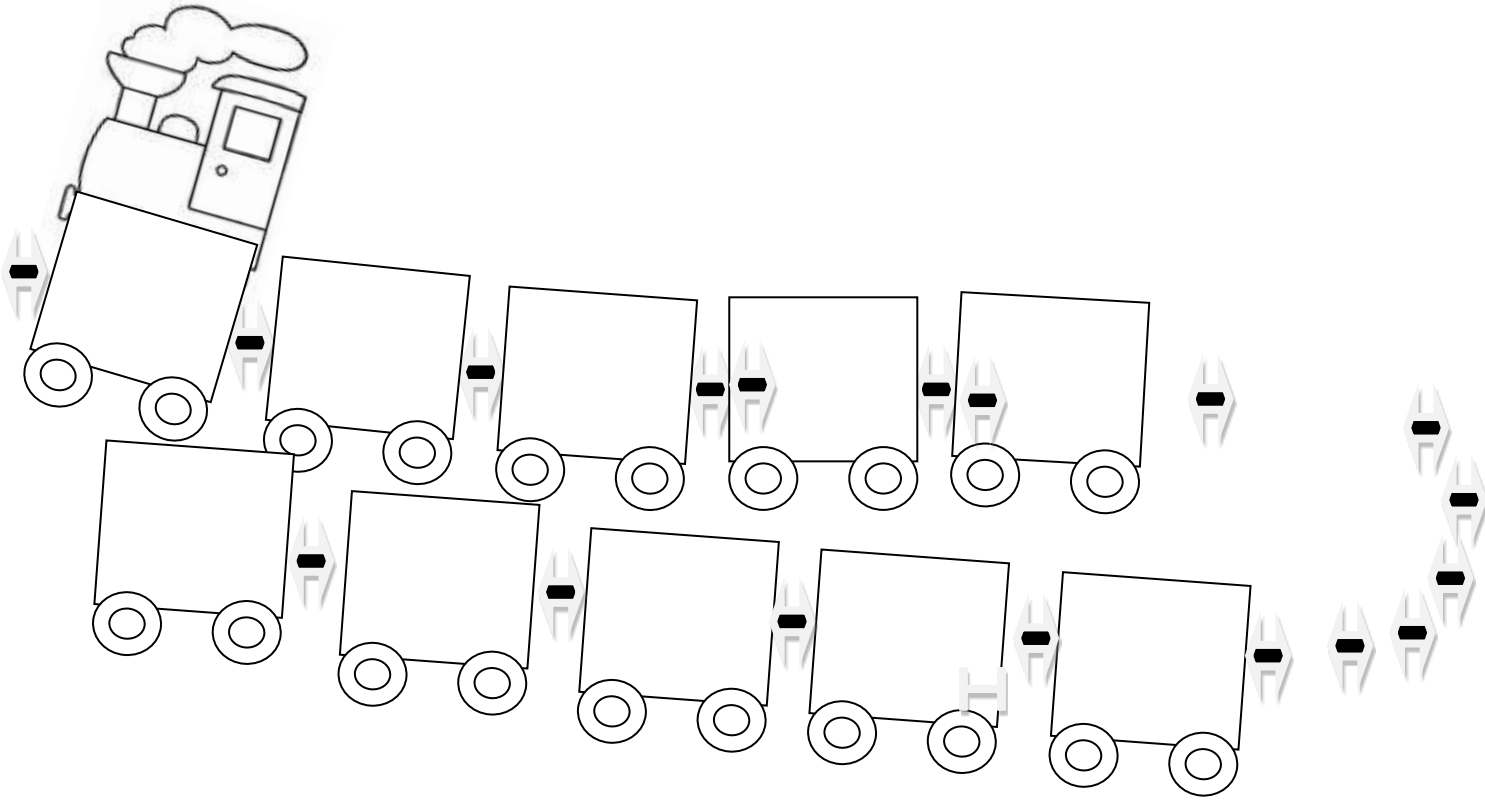

2. ऊपर लिखे नामों को वर्णमाला के हिसाब से क्रम में लिखिए :

कक्षा 3

पाठ -1 कककू

तारीख:

अ] इस चित्र में रंग भरकर तीन वाक्य लिखो :



इ] चित्र देखकर वाक्य पूरे कीजिए:



_____ जैसा लाल ।

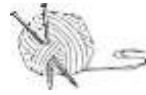

_____ जैसा मुलायम ।



_____ जैसा ठंडा



_____ जैसा काला ।



_____ जैसा सफ़ेद



_____ जैसा कड़वा ।

कक्षा 3

पाठ -शेखीबाज़ मक्खी (श्रवण)

तारीख:

पाठ की कहानी सुनाया जाने के बाद छात्र निम्नलिखित प्रश्नों का उत्तर देते हैं

१. शेर क्या कर रहा था ?

उ) _____

२.मक्खी शेर के पास जाकर क्या करने लगी ?

उ) _____

३.लोमड़ी कैसी थी ?

उ) _____

४. रास्ते में लोमड़ी से मिलनेवाले जानवरों के नाम लिखो।

उ) _____

५. मकड़ी कहाँ थी?

उ) _____

६. मकड़ी और मक्खी के चित्र बनाओ:

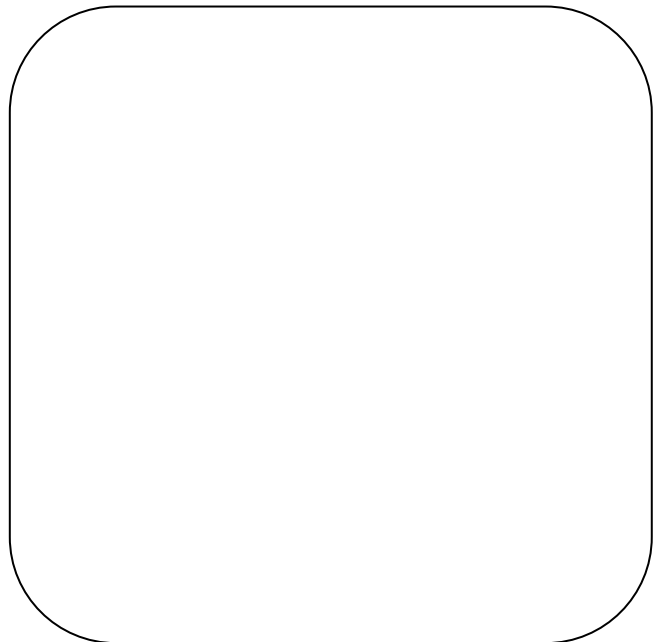
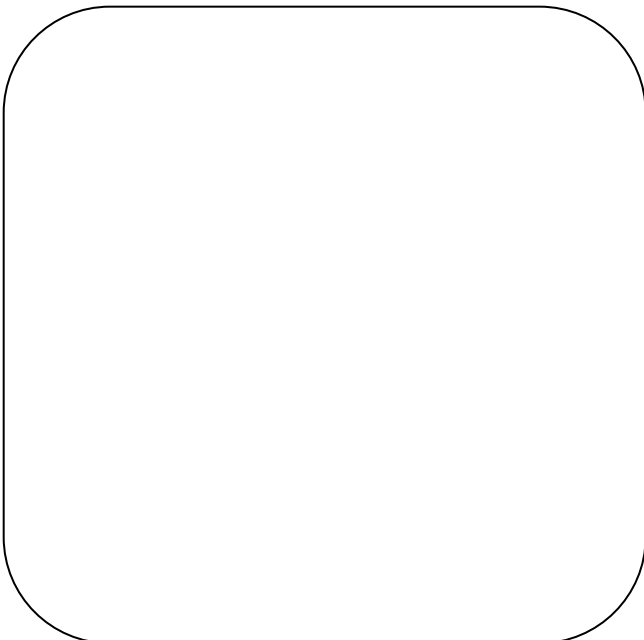

कक्षा 3

पाठ -शेखीबाज़ मक्खी

तारीख:

अ) तुम अपने घर में किन किन कीड़ों को देखते हो ठिक (✓) का निशान लगाओ:



कक्षा: 3

पाठ - चांदवाली अम्मा

तारीख:

घर की सफाई के लिए कौन - कौन सी चीजों का प्रयोग होता है ?(✓) लगाओ और नीचे दिए गए इनके नामों को सही तालिका में लिखिए :

(झाड़ू, पोछा, पानी, फिनाइल, धूल पैन, वैक्यूम क्लीनर, सिल वेब क्लीनर)

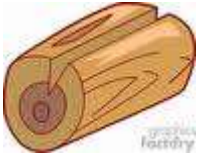

कक्षा 3

पाठ -मन करता है

तारीख:

1. नीचे लिखे शब्दों के समान अर्थ वाले शब्द लिखो :

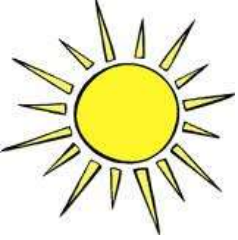

सूरज - _____



चंदा - _____



आसमान - _____



चिड़िया - _____

2. नीचे कुछ शब्द लिखे हैं। उनके अक्षरों को उलट-फेरकर अधिक से अधिक शब्द बनाओ।

बादल : बाद दल बाल लद

आसमान : _____

महाराज : _____

बारातघर: _____

कारखाना: _____

शिक्षा एवं प्रशिक्षण आंचलिक संस्थान , चंडीगढ़
कक्षा 3 हिन्दी

कक्षा 3

पाठ -- मन करता है

तारीख:

(लेखन) - वाक्य रचना - नीचे दिये चित्रों पर दो वाक्य लिखो:





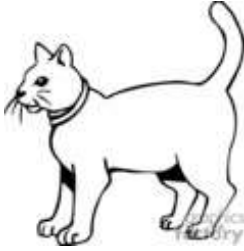

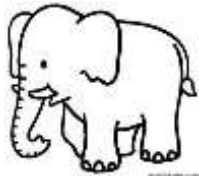



कक्षा 3

पाठ - बहादुर बित्तो

तारीख:

निम्न गद्यांश को ध्यानपूर्वक ढिए और दिए गए प्रश्नों के उत्तर लिखिए

एक किसान था। उसकी बीवी की नाम बित्तो था। एक दिन किसान ने बित्तो से कहा - सुबह जब मैं खेत में हल चला रहा था तो एक शेर ने आकार कहा - किसान - किसान अपना बैल मुझे दे दे वरना मैं तुझे खा जाऊंगा। बित्तो ने उससे पूछा - तूने क्या जवाब दिया ? किसान ने खा - मैंने कहा , तू यहीं रुक, मैं घर जाकर अपनी गाय ले आया हूँ ।

प्रश्न-१. किसान की बीवी का नाम क्या था?

उत्तर _____

प्रश्न-२ सुबह किसान क्या कर रहा था?

उत्तर _____

प्रश्न-३. शेर ने किसान से क्या मांगा ?

उत्तर _____

प्रश्न-४ लिंग बदलो : १. गाय - _____ २. _____ - शेरनी

प्रश्न-५ समानार्थक शब्द लिखिए । १. सवेरा - _____ २. उत्तर - _____

प्रश्न-६. गद्यांश से चार नामवाले सबद छाँटकर लिखो ।

उत्तर - १. _____ २. _____ ३. _____ ४. _____

जानवरों को उनके घर तक पहुँचाइए :

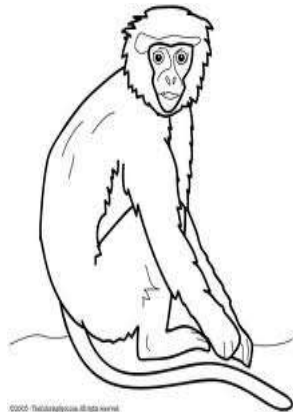
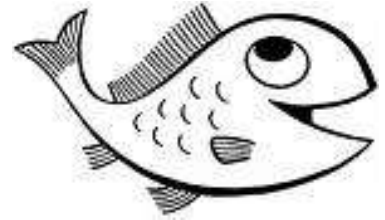
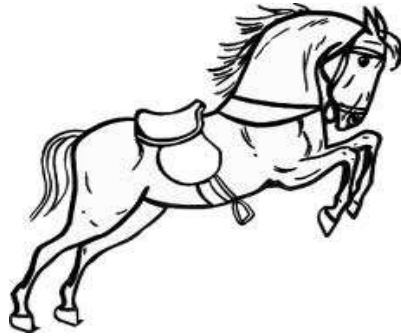

1। शब्द जाल में नीचे लिखे हुए शब्द ढूँढिए और गोला लगाइये:

शेर, डरपोक, चीख, किसान, बादशाह, राक्षसी, बित्तो, भेड़िया

ट	शे	ची	ख	कि
ड	र	पो	क	सा
प	गग	इ	ण	न
बा	द	शा	ह	प
रा	क्ष	सी	बि	त्तो
भे	ड़ि	या	धो	खा

2। नीचे लिखे वाक्यों में रेखांकित शब्द का वचन बदलकर वाक्य को दोबारा लिखो :

(क) बच्चा दूध पी रहा है।

.....

(ख) घोड़ा तेज़ दौड़ता है।

.....

(ग) गाय खेत में घुसकर फ़सल खाने लगी।

.....

(घ) माँ रोटी सेंक रही है।

.....

(ङ) औरत थाली लेकर बैठ गई।

.....

1. नीचे लिखे शब्दों में एक शब्द मिलते जुलते अर्थ वाला नहीं है। उस शब्द पर घेरा लगाओ :

(i)	धूप	सूर्य	सूरज	रवि
(ii)	हवा	वायु	आँधी	पवन
(iii)	शशि	चाँदनी	चाँद	चंदा
(iv)	बादल	मेघ	घटा	बिजली
(v)	आदमी	मनुष्य	मानव	जानवर
(vi)	जल	नीर	वारि	कपड़ा
(vii)	बाग	बगीचा	फूल	उपवन
(viii)	माता	पुष्प	सुमन	भवन
(ix)	माता	माँ	जननी	विहग
(x)	संसार	जगत	घर	दुनिया

2. निम्नलिखित शब्दों में से समान अर्थवाले शब्द ढूँढकर लिखिए :

वायु,	मेघ,	गृह,	पिता,	सूरज,	चंद्रमा,	भाई,	पानी
(क) सूर्य	-----	जल	-----				
(ख) चाँद	-----	भैया	-----				
(ग) हवा	-----	घर	-----				
(घ) बादल	-----	धूप	-----				

1] टोली बनाकर खेले जानेवाले खेलों को सही नामों से जोड़ें :

फुटबॉल



क्रिकेट



कबड्डी



हॉकी



रस्साकशी



1. दिए गए शब्दों से रिक्त स्थान भरिए।

पर, का, के, में, के लिए, से, को, की, ने

1. पोता दादी -----कहानी सुनता था।

2. वह दादी ----- गोद में लेटता था।

3. बारिश से बचने----- बाघ झोंपड़ी के पीछे बैठा था।

4. दादी ----- पोते को कहानी सुनाई।

5. पत्नी----- बात धोबी को जँच गई।

6. धोबी पंडित जी----- घर की तरफ़ चल दिया।

7. पंडित जी बारिश ----- पानी निकाल रहे थे।

8. चारपाई ----- पानी टपक रहा था।

9. उन्होंने धोबी ----- भगा दिया।

10. धोबी घास ----- गधे को ढूँढ रहा था।

2. चित्रों के मदद से यह सोचो और लिखो ये किसकी आवाज़ें हैं ?



खर्र-खर्र



भिन-भिन



तड़-तड़



भक-भक



चर-चर



ठक-ठक

कक्षा 3

पाठ -टिपटिपवा

तारीख:

1. धोबी गधे को जगह -जगह ढूँढता है। मतलब धोबी ने गधे को कई जगह ढूँढा। अब इसी तरह से नीचे दिए गए वाक्यों को दोबारा लिखिए।

1. दादी पोते को तरह-तरह की कहानियाँ सुनाती थी।

2. माँ ने बेटे को बार-बार पढ़ने के लिए कहा।

3. राजप्पा जगह-जगह जाकर टिकट इकट्ठी करता था।

4. मोहन ने लिख-लिख कर अभ्यास किया।

2. धोबी ने बाघ को खूंटों से बाँध दिया। सोचो और बताओ, खूंटों से और किन - किन जानवरों को बाँधा जाता है ?

1. _____

2. _____

3. _____

4. _____

5. _____



1. सही शब्द चुनकर रिक्त स्थान भरो :

हक हड़पा आँखे पछताने फ़ैसला महक बराबर

1. मुझे ----- रोटी की आती ।
2. क्या मेरी दो----- नहीं है ?
3. जो पहले देखे----- उसका है रोटी पर ।
4. रोटी किसकी मैं इसका ----- करूँगा ।
5. मुँह थक गया ----- करते- करते ।
6. अब ----- से क्या होता, बंदर ----- रोटी ।





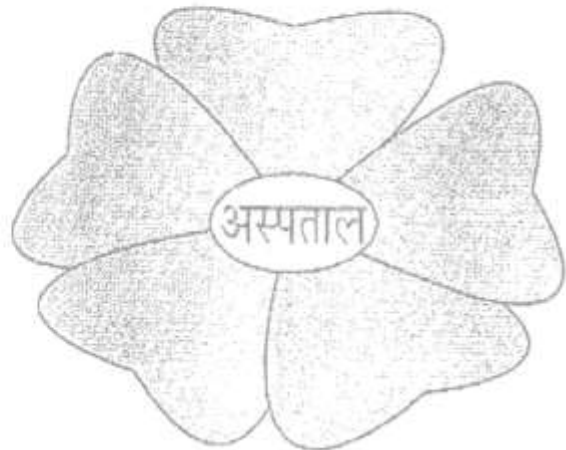

2। पाठ में “कचहरी” शब्द आया है। कचहरी से जुड़े शब्द कौन से हैं ?



इसी प्रकार “स्कूल” और “अस्पताल” से जुड़े शब्द सोच कर लिखो।

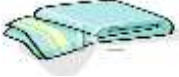

1. तोलने वाले नापने वाले और मापने वाले चीज़ों को सही जगह पर ठीक (✓) लगाइए :

चीजे			
			
			
			
			

2. अपनी पसंद, नपसंद, सूँघकर , देखकर , महसूसकर , सुनकर , चखकर बताते है । नीचे दी गई चीज़ों के बारे में आप कैसे पता लगाएँगे कि ये आपको पसंद है या नहीं ?













कक्षा 3

पाठ -- अक्ल बड़ी या भैंस

तारीख:

1. "हाँ" या "नहीं" में उत्तर लिखो ।

- (क) अक्ल कठिन काम को भी सरल बना देती है । (-----)
- (ख) पहलवान ताकतवर तो था, पर अक्लमंद नहीं था । (-----)
- (ग) पहलवान को अपनी ताकत पर घमंड था । (_____)
- (घ) आफंती पहलवान को शहर की दीवार फाँदने के लिए कहा । (-----)
- (ङ.) शक्ति का प्रयोग करने के लिए भी अक्ल की जरूरत होती है । (-----)

3. वाक्यों की खाली जगह में रेखांकित शब्दों के विलोम शब्द लिखो :

- (क) भारती बाहर खड़ी रही पर रमेश अंदर चला गया ।
- (ख) रुमाल बड़ा हल्का था, पत्थर बाँधने से वह ----- हो गया ।
- (ग) इस तरह की उल्टी -----बातें मेरी समझ में नहीं आतीं ।
- (घ) तुम हर समय उसकी बुराई करते रहे हो, कभी तो ----- भी किया करो ।
- (ङ.) इतना धीरे चलने से काम नहीं चलेगा, ज़रा ----- चलो ।
- (च) यह तो बड़ी आम-सी बात है, इसमें कुछ भी ----- नहीं ।
- (छ) महता जी ने कपड़े का काम शुरू तो किया था पर पैसे की कमी के कारण ----- करना पड़ा ।

1. दी गई कविता को पढ़कर महीनों के नाम क्रम से लिखिए।
जनवरी से हुई नई शुरुआत, फरवरी लई फूलों की बहार।
मार्च में बिखरे होली के रंग, अप्रैल आई बैसाखी के संग।
मई में छुट्टियों ने दी दस्तक, जून में लू से मिली फुरसत।
जुलाई में रहा त्योहारों का इंतज़ार, अगस्त में बढ़ा भाई-बहन का प्यार।
सितंबर ने गर्मी से राहत दिलाई, अक्टूबर ने रामलीला दिखाई।
नवंबर में छाई मस्ती की बहार, दिसंबर लाया बहुत- से उपहार।

-
- | | |
|---------|----------|
| 1. | 7. |
| 2. | 8. |
| 3. | 9. |
| 4. | 10. |
| 5. | 11. |
| 6. | 12. |
-

● उत्तर दीजिए :

1. अगर आज बुधवार है , तो :

क) कल क्या था ? _____

ख) कल कौन-सा दिन आएगा ? _____

2. शनिवार और सोमवार के बीच कौन-सा दिन है ? _____

3. शनिवार से पहले कौन-सा दिन है ? _____

4 मंगलवार के बाद कौन-सा दिन है ? _____

● लिखो :

सात रंगों के नाम	सात दिनों के नाम

1. दिए गए चित्रों के नाम लिखकर स्थान भरिए :

1. गुरुजी पर जा रहे थे ।
2. मम्मी बना रही हैं ।
3. बंटी खा रहा है ।
4. बुलबुल पर बैठी है ।
5. बच्चे से खेल रहे हैं ।

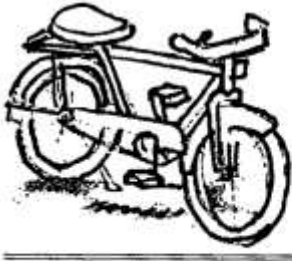

कक्षा 3

पाठ -मीरा बहन और बाघ





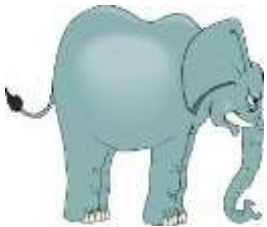
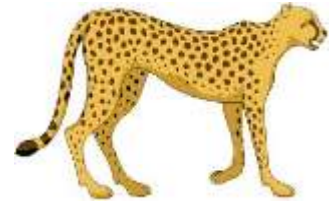
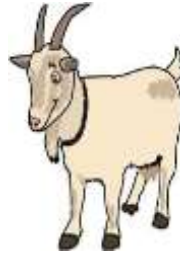
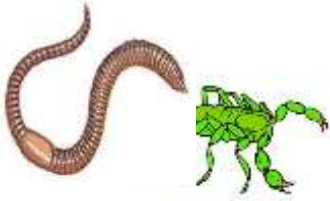

तारीख:

1. कौन-कौन से जानवर खतरनाक है उन चित्रों को रंग भरकर नीचे नाम लिखो :

भैंस बकरी साँप केंचुआ भालू शेर ऊँट
चीता कुत्ता विच्छू तेंदुआ कबूतर हाथी घोड़ा

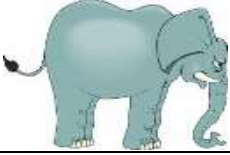

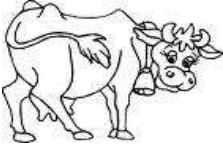
बोलियों लिखो :

	भैंस की	रँभाना
	घोड़े की	
	हाथी की	
	बकरी की	
	शेर की	
	गाय की	
	कुत्ते की	

कक्षा 3

तारीख:

चित्र का वर्णन करो :



कक्षा 3

पाठ - जब मुझको साँप ने काटा

तारीख:

1. शब्द चुनकर वाक्य पूरे करो ।

1. अहाते एक साँप रेंग रहा था। (में, मैं)
2. उसे लेकर नानी के पास दौड़ गया। (में, मैं)
3. साँप नारियल के खोल की जाने लगा। (ओर, और)
4. नाना दौड़े आए मेरी उँगली मो देखा। (ओर, और)
5. बर्तन उँगली डाले..... चुपचाप बैठा रहा। (में, मैं)
6. मैंने नाना की देखा उन्हें बुछ बताना चाहा। ((ओर, और)

2. सही शब्द चुनकर लिखो :

1. नारियल के खोल में एक _____ छिप गया। (साँप/कीड़ा)
2. नन्हा साँपहुआ झाड़ी में गायब हो गया। (रेंगता/दौड़ता)
3. एक बूढ़े आदमी ने..... किया। (इलाज/झाड़फूंक)
4. बच्चे को एक..... ने काटा था। (बर्/साँप)

कक्षा 3

पाठ -- जब मुझको साँप ने काटा

तारीख:

1. रंग भर कर साँप के बारे में चार या पाँच वाक्य लिखिए :

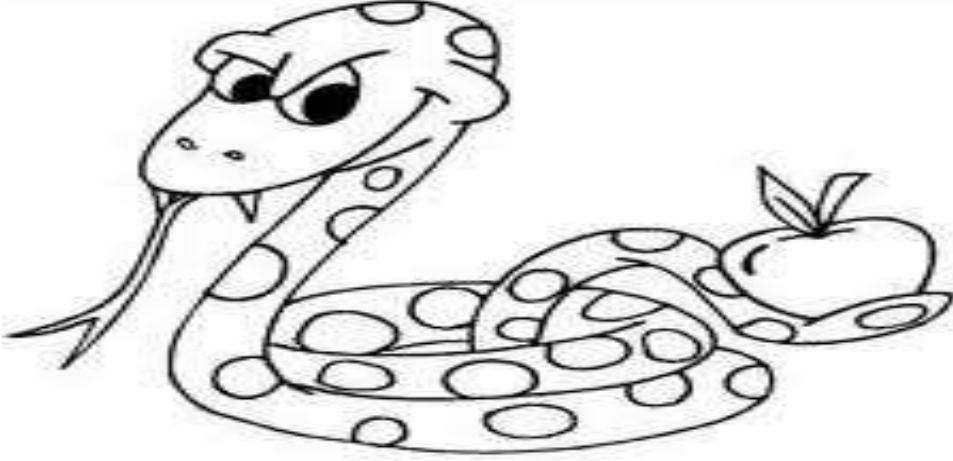

इनके पास तुमने किनको उड़ते देखा है चित्रों को जोड़ों :



गंदे इकट्ठे पानी के ऊपर



फूलों पर



जलते बल्ब के ऊपर

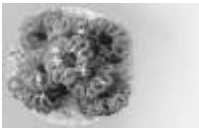

हलवाई की मिठाइयों पर



खेतों में



कचरे के ढेर पर



पानी माला पैसा दिशा परिणाम लेकिन
 जवाब हार जाना सेब केला आदि फल
 आने वाला दिन नीरपंख मगरमच्छ किंतु
 बीता हुआ दिन

उदाहरण के अनुसार ऊपर दिए गए शब्दों को सही तालिका में लिखिए

उदाहरण -	जल	पानी	नीर
	हार		
	उत्तर		
	फल		
	मगर		
	पर		
	कल		

4. समान तुक वाले शब्द बनाओ :

(ऐसा)	(आते)	(यहाँ)	(कल)
○	○	○	○
○	○	○	○
○	○	○	○

कक्षा 3

पाठ -- सबसे अच्छा पेड़

तारीख:

1. इनके स्वादों को याद करो और सही स्वाद को सही जगह लिखिए :

मीठा

कड़वा

नमकीन

खट्टा

तीका









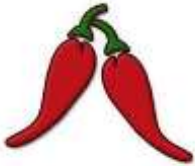







कक्षा 3

पाठ -- सबसे अच्छा पेड़

तारीख:

1. संकेत देखकर पूरे कीजिए और शब्द जाल में उत्तर लिखिए :

					<u>बाएँ से दाएँ</u>	<u>ऊपर से नीचे</u>
1	10			2	1..... के पेड़ से दातुन बनाते हैं। (दो अक्षर)	2. कच्चे आम से बनाते हैं। (तीन अक्षर)
	म			अ	3. रबड़ के पेड़ में से रस निकलता है। (तीन अक्षर)	5. नारियल के खोपरे से निकलता है। (दो अक्षर)
8	7	6	X		4. रबड़ के गाड़ियों में लगते हैं। (तीन अक्षर)	6. नारियल की से डोरी बनाते हैं। (दो अक्षर)
		4			9. पेड़ों से तरह-तरह के मिलते हैं। (दो अक्षर)	7. रूई से धागा बनाकर हम सूती..... बनाते हैं। (तीन अक्षर)
क		टा		5	10.....के पौधे की फली से हरे रंग के गोल-गोल दाने निकलते हैं।(तीन अक्षर)	8. पेड़ की से कुर्सी बनाते हैं। (तीन अक्षर)
	ड़े	X	X	ते		
3		या	फ	9		

कक्षा 3

पाठ -- सबसे अच्छा पेड़

तारीख:

1. कुछ शब्दों के अक्षर उलट पलट गए हैं। उन्हें सही क्रम से लिखकर शब्द बनाओ :

न आ मा स

.....

र ख दा र ब

.....

वा न्य द ध

.....

वा वि र र

.....

य ना ल रि

.....

ला मू धा सा

.....

क ना त ख र

.....

का मु त ला

.....





2. चार-चार फलों के नाम लिखो :

गुठली वाले फल	बिना गुठली वाले फल

3. वचन बदलिए :

एकवचन	बहुवचन	एकवचन	बहुवचन
रस्सी		चीज़	
टोकरी		केला	
चटाई		सब्ज़ा	

1. बूझो तो जानें।

<p>बड़ा- सा पत्ता मेरा भाई रखते मुझको सब हलवाई खाना मुझ पर डाल के खाते दावत का मज़ा सब उड़ाते ।</p>	 <p>.....</p>
 <p>.....</p>	<p>एक तरफ़ से मैं हूँ गोल एक तरफ़ है मुझपे नोक मैं हूँ ऐसे पेड़ का पत्ता लोग पूजते मुझे हमेशा।</p>
<p>मेरी खुशबू है अनमोल लाते मुझको सारे लोग दाल में लगता मेरा तड़का सांभर बनता बिन मेरे न अच्छा ।</p>	 <p>.....</p>
 <p>.....</p>	<p>मुझपे डाल के मीठी सुपारी खाती मुझको दुनिया सारी लाल कर देता सो दाँत मेरी आदत है खराब</p>

पता लगाओ और लिखो :



जो पत्ता

- 1 खाने से मुँह और जीव लाल हो जाते हैं । _____ के पत्ते
- 2 पीस कर हाथ पैर और बालों पर लगाई जाती है । _____ के पत्ते
- 3 इस पत्तों की नसों से झाड़ू बनाई जाती हैं । _____ के पत्ते
- 4 पूजा के कार्यों में प्रयोग किया जाता है । _____ के पत्ते
- 5 पत्तियाँ पीसकर चटनी बनाई जाती है । _____ के पत्ते
- 6 इन्हें मसालों की तरह प्रयोग किया जाता है । _____ के पत्ते
- 7 इसे सॉभार दाल कढ़ी आदि में डाला जाता है । _____ के पत्ते
- 8 इन्हें सब्जी बनाने के काम आते है । _____ के पत्ते ।



कौन बाँग लगा रहा है ? (मुर्गा / मुर्गी)
_____ बाँग लगा रहा है ।

दाना कौन चुग रहा है ? (मुर्गा / मुर्गी)
दाना _____ चुग रही है ।

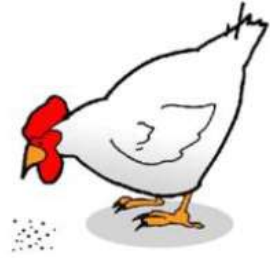

गेंद से कौन खेल रहा है ? (बच्चा / बच्ची)
गेंद से _____ खेल रहा है ।

पुस्तक कौन पढ़ रहा है ? (बच्चा / बच्ची)
पुस्तक _____ पढ़ रही है ।



सड़क कौन पार कर रहा है ? (बूढ़ा / बुढ़िया)
सड़क _____ पार कर रहा है ।

रौकर पर कौन बैठा है ? (बूढ़ा / बुढ़िया)
रौकर पर _____ बैठी है ।



Where To Look From?

1. Underline the correct view to look at these things:

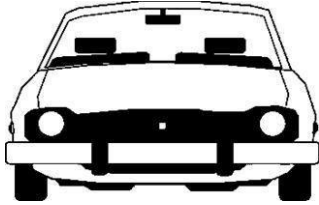

TOP / SIDE / FRONT

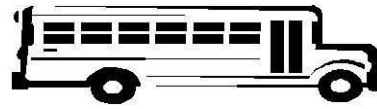

TOP / SIDE / FRONT

2. Observe the following figures and complete the other half.

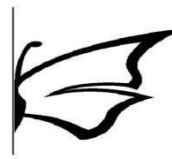

3. Complete these figures to form the basic shapes.

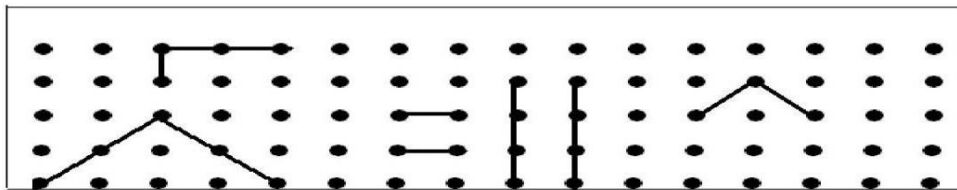

4. Draw the Line of Symmetry for the following:

A

M

U

W

E

B

C

D

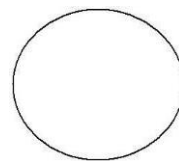
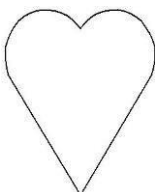

Fun with Numbers

1. Fill in the missing numerals

200					205
478					483
765					770

2. Write the number names for the following

a) 199 _____

b) 213 _____

c) 341 _____

d) 605 _____

3. Arrange the following numbers in ascending order

412, 521, 356, 800, 734, 513, 146, 681

2. Arrange the following numbers in descending order

511, 621, 133, 666, 876, 167, 412, 764,

3. How many triangles can you find in this figure?

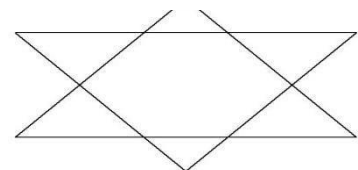

4. Who am I ?

1) My Ones digit is four. My Tens digit is 3 more than my Ones digit.

I am the number _____.

2) My Ones digit is five. My Tens digit is 2 more than my Ones digit.

My Hundreds digit is 1 less than my Ones digit. I am the number _____.

3) My Ones digit is zero. My Tens digit is 7 more than my Ones digit.

My Hundreds digit is 6 more than my Ones digit. I am the number _____.

1. Colour the Numbers as directed.

18	9	132
4	458	45
909	77	5

a. 1 digit numbers GREEN.

b. 2 digits numbers YELLOW.

c. 3 digits numbers RED.

2. Write the Expanded form of the following Numbers.

a) $732 = 700 + 30 + 2.$

b) $123 = \underline{\hspace{2cm}}$

c) $390 = \underline{\hspace{2cm}}$

d) $589 = \underline{\hspace{2cm}}$

e) $666 = \underline{\hspace{2cm}}$

f) $909 = \underline{\hspace{2cm}}$

g) $576 = \underline{\hspace{2cm}}$

h) $345 = \underline{\hspace{2cm}}$

i) $809 = \underline{\hspace{2cm}}$

j) $200 = \underline{\hspace{2cm}}$

k) $851 = \underline{\hspace{2cm}}$

l) $454 = \underline{\hspace{2cm}}$

m) $333 = \underline{\hspace{2cm}}$

n) $666 = \underline{\hspace{2cm}}$

2. Count backwards and fill in the blanks:

a) 19 , , , , , ,

b) 40 , , , , , ,

c) 68 , , , , , ,

d) 54 , , , , , ,

e) 14 , , , , , ,

Give and Take

1) Add the given numbers using the grid

91	92	93	94	95	96	97	98	99	100
81	82	83	84	85	86	87	88	89	90
71	72	73	74	75	76	77	78	79	80
61	62	63	64	65	66	67	68	69	70
51	52	53	54	55	56	57	58	59	60
41	42	43	44	45	46	47	48	49	50
31	32	33	34	35	36	37	38	39	40
21	22	23	24	25	26	27	28	29	30
11	12	13	14	15	16	17	18	19	20
1	2	3	4	5	6	7	8	9	10

a) $45 + 5 =$ _____

c) $32 + 8 =$ _____

b) $60 + 7 =$ _____

d) $57 + 9 =$ _____

e) $76 + 12 =$ _____

f) $58 + 14 =$ _____

g) $22 + 18 =$ _____

h) $30 + 17 =$ _____

i) $27 + 19 =$ _____

j) $60 + 27 =$ _____

2) Subtract the given numbers using the grid:

a) $45 - 5 =$ _____

c) $32 - 8 =$ _____

b) $60 - 7 =$ _____

d) $57 - 9 =$ _____

e) $48 - 29 =$ _____

f) $76 - 34 =$ _____

a) $45 - 12 =$ _____

c) $22 - 18 =$ _____

b) $60 - 14 =$ _____

d) $54 - 9 =$ _____

3. Add mentally and write the number:

a) 11 more than 20 _____

b) 10 more than 49 _____

c) The sum of 28 and 10 is _____

d) 9 added to 41 gives _____

e) 19 added to 7 gives _____

f) 10 less than 100 is _____

g) 12 less than 60 is _____

h) Take away 20 from 70 _____

i) 20 more than 29 _____

j) 19 added to 15 gives _____

Long and Short

1. Fill in the blanks

a) The standard unit for measuring length is _____

b) 1 m = _____ cm

c) 4 m = _____ cm

d) 8 m = _____ cm

e) 2 m 50 cm = _____ cm

f) 7 m 90 cm = _____ cm

g) 9m 10 cm = _____ cm

i) 500 cm = _____ m

j) 700 cm = _____ m

k) 850 cm = _____ m _____ cms

2. Estimate the lengths of the following objects and tick the right answer

a) Length of a blackboard 

b) Length of a cot 

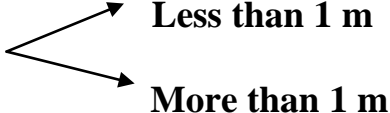
c) Length of a pillow 

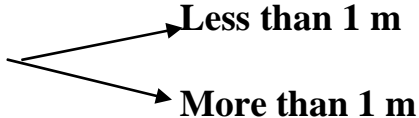
d) Length of a door 

3) Work out the steps in your mind and write the answers directly in the box.

a) $44 + 22 =$

b) $19 + 71 =$

c) $48 + 42 =$

d) $33 + 37 =$

e) $67 + 33 =$

f) $80 + 20 =$

g) $94 - 22 =$

h) $86 - 10 =$

i) $49 - 9 =$

j) $88 - 18 =$

k) $70 - 70 =$

l) $40 - 0 =$

Shapes and Designs

1. Name these shapes.

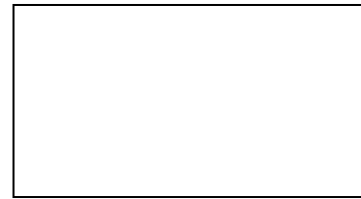
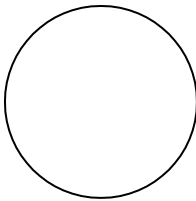
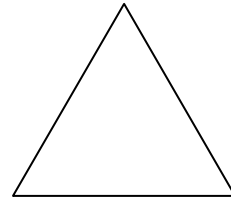

I. Using a scale measure the following :

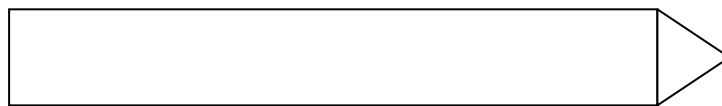

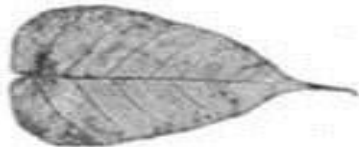
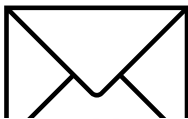

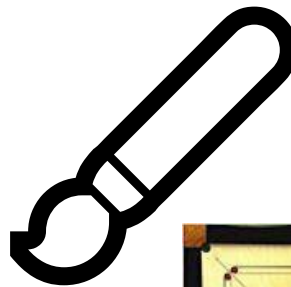

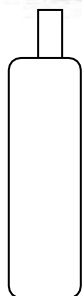

ERASER

Count the number of Edges and Corners in these figures.

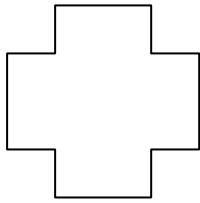

Edges = _____

Corners = _____



Edges = _____

Corners = _____

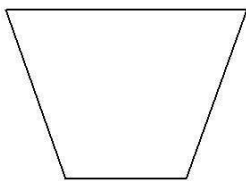

Edges = _____

Corners = _____

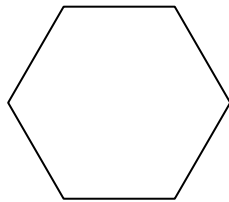

Edges = _____

Corners = _____

Count the number of squares, rectangles, triangles and circles in the following picture.

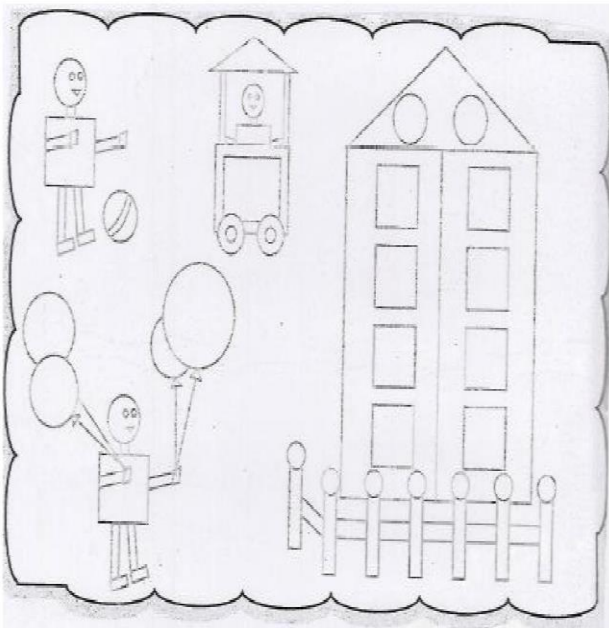

Number of  _____

Number of  _____

Number of  _____

Number of  _____

Fun with Give and Take

1. Find the answers mentally:

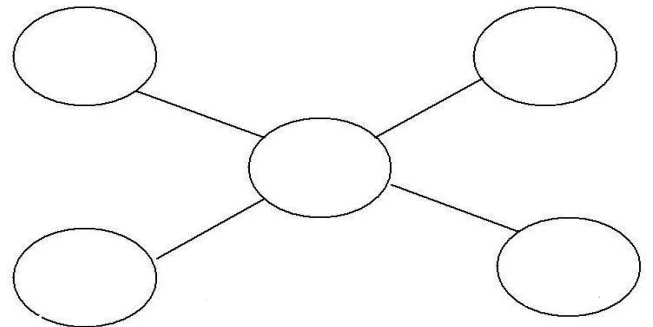
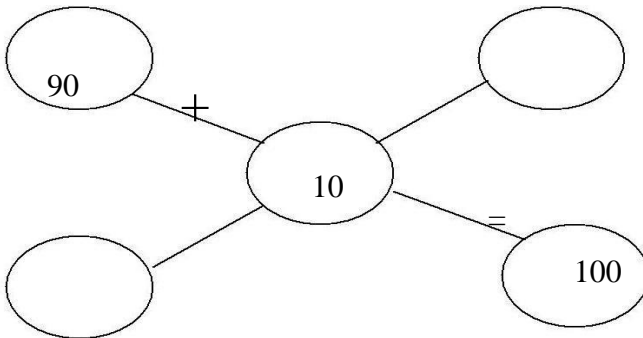
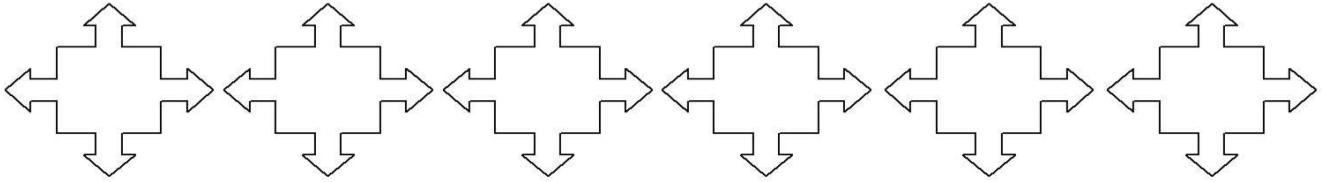

Check the subtraction answer using addition.

	8	5	3
-	2	8	4

+			

ii. Solve the following:

$$\begin{array}{r} 18 \\ - 9 \\ \hline \\ \hline \end{array}$$

$$\begin{array}{r} 16 \\ - 8 \\ \hline \\ \hline \end{array}$$

$$\begin{array}{r} 25 \\ - 7 \\ \hline \\ \hline \end{array}$$

$$\begin{array}{r} 33 \\ - 17 \\ \hline \\ \hline \end{array}$$

$$\begin{array}{r} 235 \\ - 149 \\ \hline \end{array}$$

$$\begin{array}{r} 470 \\ - 368 \\ \hline \end{array}$$

$$\begin{array}{r} 500 \\ - 276 \\ \hline \end{array}$$

$$\begin{array}{r} 604 \\ - 457 \\ \hline \end{array}$$

TIME GOES ON

I. How long does it take? Use the words given below:

Seconds	minutes	hours	days	months
---------	---------	-------	------	--------

- a. To drink a glass of water _____
- b. To brush your teeth _____
- c. For the sun to rise _____
- d. To blink your eyes _____
- e. To switch on the light _____
- f. For a plant to grow _____
- g. To do your homework _____
- h. To eat your dinner _____
- i. To have a bath _____
- j. To pack your school bag _____

II. What will the time be?

- a. 1 hour after 10:30 _____
- b. 15 minutes after 3:30 _____
- c. 10 minutes before 1:20 _____
- d. 20 minutes before 5:00 _____

III. Draw the clocks and show the following time:

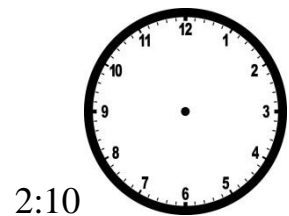
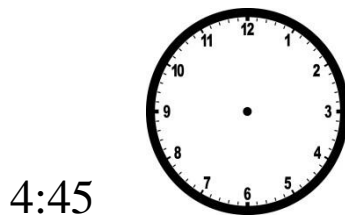
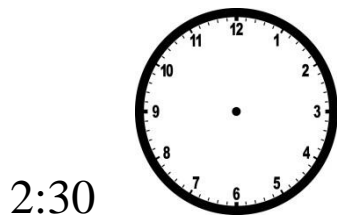

IV. Fill in the blanks using the word Morning or Evening.

- a) Rosy gets up at _____ and goes for morning walk.
- b) At _____ she has her milk.
- c) Rosy takes a bath at _____.
- d) At _____ rosy has her lunch.
- e) Rosy takes a nap at _____.
- d) Rosy plays with me at _____.
- e) Rosy goes to bed at _____.
- f) 1 hour = _____ minutes.
- g) _____ Hand is smaller than the _____ hand.
- h) At noon and midnight both hands point to _____
- i) There are _____ hours in a day.
- j) At quarter past four the minute hand is at _____

Who is heavier?

I. Tick the object that will weigh more:

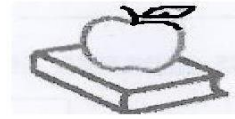

II. Encircle the heavier weight:

a) 5kg

8kg

b) 250g

175g

c) 50kg

276kg

d) 100kg

100g

III. What will you use g or kg to measure the weight of the following:

a) A pencil _____

b) A big watermelon _____

c) A cake _____

d) An orange _____

e) A sack of wheat _____

f) A spoon of sugar _____

g) An apple _____

h) A big pumpkin _____

II. Match the following weights and use = sign and write in the given space:

1 kg of potato

2000g of beans

2 kg of tomatoes

4000g of wheats

4 kg of onions

1000 g of chillies

1. _____

2. _____

3. _____

How Many Times?

I. Complete the table

Repeated Addition	In words	Multiplication
$2 + 2 + 2$	3 groups of 2 are 6	$3 \times 2 = 6$
$7 + 7 + 7 + 7$	4 groups of ___ are ___	___ x ___ = ___
$8 + 8 + 8$		
$9 + 9 + 9 + 9 + 9$		
$10 + 10$		

II. Encircle the multiples of 5:

1, 2, 5, 6, 10, 12, 15, 17, 20, 24, 25, 30, 35, 40

III. Look at the pattern and complete:

a) 2, 4, 6, 8, 10, _____, _____, _____

b) 5, 10, 15, 20, _____, _____, _____

c) 6, 12, 18, 24, _____, _____, _____

d) 20, 40, 60, 80 _____, _____, _____

e) 40, 80, 120, 160, _____, _____, _____

f) 15, 30, 45, 60, _____, _____, _____

IV. Insert the signs (+, -, or x):

a) $10 \quad \boxed{x} \quad 2 = 20$

e) $4 \quad \boxed{} \quad 4 = 0$

b) $4 \quad \boxed{} \quad 4 = 8$

f) $6 \quad \boxed{} \quad 10 = 16$

c) $8 \quad \boxed{} \quad 1 = 8$

g) $2 \quad \boxed{} \quad 5 = 10$

d) $10 \quad \boxed{} \quad 5 = 15$

h) $10 \quad \boxed{} \quad 5 = 50$

I. Write the multiplication facts for the following:

Number	Multiplication	Facts
36	9 x 4	4 x 9
42		
80		
65		
14		

II. Find the product:

114 x 6	432 x 7	257 x 4	603 x 2	230 x 5
---------	---------	---------	---------	---------

III. Find the product by coloumn method:

$\begin{array}{r} 75 \\ \times 15 \\ \hline \end{array}$	$\begin{array}{r} 47 \\ \times 14 \\ \hline \end{array}$	$\begin{array}{r} 91 \\ \times 22 \\ \hline \end{array}$	$\begin{array}{r} 83 \\ \times 30 \\ \hline \end{array}$	$\begin{array}{r} 32 \\ \times 19 \\ \hline \end{array}$
----------------------------------------------------------	----------------------------------------------------------	----------------------------------------------------------	----------------------------------------------------------	----------------------------------------------------------

IV. Fill in the blanks:

a) $21 \times 100 = \underline{\hspace{2cm}}$

b) $\underline{\hspace{2cm}} \times 100 = 1700$

c) $87 \times 200 = \underline{\hspace{2cm}}$

d) $9 \times 300 = \underline{\hspace{2cm}}$

e) $66 \times 10 = \underline{\hspace{2cm}}$

f) $10 \times 900 = \underline{\hspace{2cm}}$

g) $607 \times \underline{\hspace{2cm}} = 6070$

h) $700 \times 10 = \underline{\hspace{2cm}}$

i) $\underline{\hspace{2cm}} \times 100 = 5000$

j) $40 \times 10 = \underline{\hspace{2cm}}$

k) $10 \times 85 = \underline{\hspace{2cm}}$

l) $\underline{\hspace{2cm}} \times 10 = 1460$

Play with Patterns

I. Complete the following number patterns:

i. 5, 10, 15, 20, _____, _____, _____, _____

ii. 8, 18, 28, 38, _____, _____, _____, _____

iii. 99, 199, 299, 399, _____, _____, _____, _____

iv. 275, 274, 273, 272, _____, _____, _____, _____

II. Complete the following statements:

i. All numbers that end with 0, 2, 4, 6 and 8 are called _____ numbers.

ii. All numbers that end with 1, 3, 5, 7 and 9 are called _____ numbers.

iii. If we add 1 to an even number we get a _____ number.

iv. If we add 1 to a odd number we get an _____ number.

v. If we add an odd number to a odd number we get an _____ number.

vi. If we add an even number to a odd number we get a _____ number.

vii. The greatest 1 digit even number is _____.

viii. The smallest 1 digit odd number is _____.

ix. The greatest 2 digit odd number is _____.

x. The smallest 2 digit odd number is _____.

III. Solve the following and write even or odd against each answer:

a.	15	+	10	=	25	Odd
b.	28	+	14	=		
c.	54	-	10	=		
d.	68	-	60	=		
e.	4	x	5	=		
f.	7	x	7	=		

Colour as directed:

- 1 digit odd numbers – Yellow
- 1 digit even numbers – Orange
- 2 digit odd numbers – Blue
- 2 digit even numbers – green
- 3 digit odd numbers – pink
- 3 digit even numbers - red

12	7	569	124	65
23	476	3	231	49
100	347	541	670	54
84	900	675	1	98
16	477	55	609	8

I. Some secret messages are given below. Decode these messages and write:

a) 1g 2o 3o 4d 7m 5o 8r 9n 8i 2n 5g

b) 11w 2e 5l 8c 6o 3m 0e

c) AAWBBH NNE MMR DDE VVA WWR MME KKY GGO XXU?

d) XXISSaTTmEEiFFnQQtVVhMMeAApUUICCaHHyZZgAArUUo
MMuLLnRRd

II. Arrange these names in alphabetical order and number these names in the box:

Mohan

Shilpa

Lila

Nandu

Chitra

Pawan

Venu

Ahmed

Zeenat

Sameer







Jugs and Mugs

1. Complete the following table according to the example given:

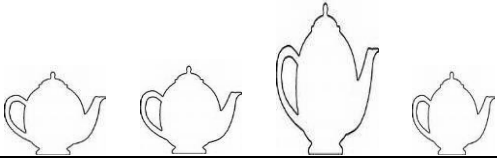
Eg. 1 litre = 1000 millilitres

LITRE	MILLILITRE
Half a litre	
Three fourth litre	
One fourth litre	
Two litres	
Two and a half litre	
Three litres	
Five and a quarter litre	
Six litres	
Six litres and half litre	

Which container holds the most liquid? Tick the correct figure:

<p>Which teapot contains the most tea?</p> 	<p>Which glass holds the most juice?</p> 
<p>Which mug holds the most cocoa?</p> 	<p>Which bottle holds the most bubble bath?</p> 
<p>Which glass holds the least juice?</p> 	<p>which bottle holds the least bubble bath?</p> 

1. Write out the amount of liquid by using the scale:

Note : 1 litre = 1000 millilitres or 1000 ml one marking on the jar = 100 millilitres or 100ml

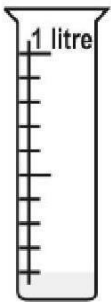

How much liquid? Read the scale.
Write the answer.

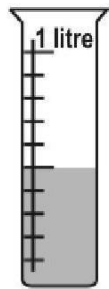

How much liquid? Read the scale.
Write the answer



How much liquid? Read the scale.
Write the answer

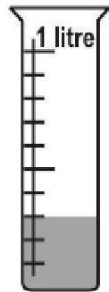

How much liquid? Read the scale.
Write the answer.

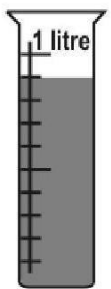

How much liquid? Read the scale.
Write the answer



How much liquid? Read the scale.
Write the answer.

Can we share?

1. Make equal groups and write the division facts for the following;

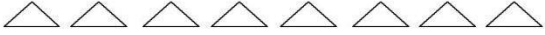
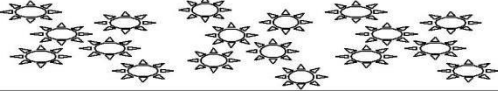
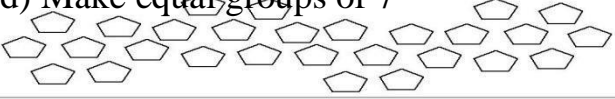
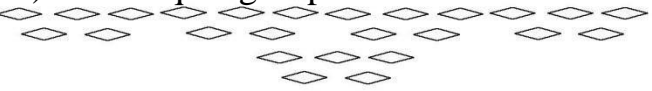
<p>a) Make equal groups of 4</p> 	<input type="text"/> <input type="text"/> <input type="text"/>
<p>b) Make equal groups of 2</p> 	<input type="text"/> <input type="text"/> <input type="text"/>
<p>c) Make equal groups of 6</p> 	<input type="text"/> <input type="text"/> <input type="text"/>
<p>d) Make equal groups of 7</p> 	<input type="text"/> <input type="text"/> <input type="text"/>
<p>e) Make equal groups of 5</p> 	<input type="text"/> <input type="text"/> <input type="text"/>

Write 2 division facts for the following multiplication facts

Ex $6 \times 3 = 18$	$18 \div 3 = 6$	$18 \div 6 = 3$
$7 \times 4 = 28$		
$9 \times 5 = 45$		
$6 \times 8 = 48$		
$5 \times 7 = 35$		
$8 \times 9 = 72$		
$3 \times 8 = 24$		
$7 \times 9 = 63$		

Smart Charts

I Read and write the number for the given tally marks.

a)

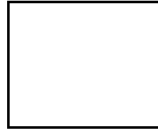
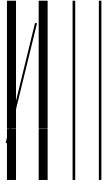

b)

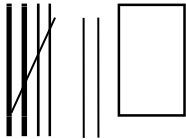

c)

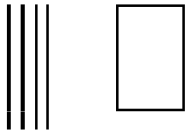

2. Draw tally marks for the following numbers

a) 7

b) 9

c) 13

d) 21

e) 19

f) 25

Read the table given below about the hobbies of students of class III Represent the data pictorially using smilies (☺ = 1 student)

Painting	10
Dancing	8
Music	5
Craft	15
Cycling	13
Gardening	14
Stamp collection	10
Reading	9

- (a) Which is the most popular hobby? _____
- (b) Which is the least popular hobby? _____
- (c) How many more children like craft than music? _____
- (d) How many students like gardening? _____
- (e) What is the difference between the number of students who prefer reading and those who prefer music? _____

The table given below shows the number of absentees in class III in a week.

Days	No of students Absent
Mon	4
Tue	3
Wed	8
Thurs	9
Fri	5
Sat	10

Represent the same in the form of a bar chart:
(1 cm = 1 student)

Mon Tue Wed Thu Fri Sat

ZONAL INSTITUTE OF EDUCATION & TRAINING, CHANDIGARH

Class: III

Sub: MATHS

Rupees and Paise

I) Convert the following into Paise:-

- a) 1 Rupee = _____ Paise b) 9 Rupees = _____ paise
c) 6 Rupees = _____ paise d) Rs 7.75 = _____ paise
e) Rs 8.50 = _____ paise f) Rs 9.25 = _____ paise

II) Convert the following into Rupees:-

- a) 375 paise = Rs. b) 700 paise = Rs.
c) 75 paise = Rs. d) 810 paise = Rs.
e) 250 paise = Rs. f) 645 paise = Rs.

1. Complete the bill and write the total money spent

Item	Cost per item	Quantity	Total Cost
Water Bottles	RS. 50.00	4 water bottles	
Pencil Boxes	Rs. 20,00	3 pencil boxes	
Socks	Rs. 35.00	2 pairs of socks	
Shirts	Rs. 75.00	3 shirts	
Poster colours	Rs. 40.00	4 poster colours	

i) 50 paise coins make 5 rupees.

ii) i) 10 rupee notes make Rs.100.

ii) 500 rupee notes make Rs.1000.

iv) Rs. 10 + Rs. 50 =

